

DEAR CUSTOMERS :

Thank you for buying **T-rex** of **PGO Scooter**. It is a fact that the efficiency and sustaining life of each scooter depend heavily on the operating method of each user. Thus this owner's manual will provide you a precise knowledge of easy adjusting, sustaining and precaution for your scooter. We hope you will read and check it carefully.

This manual includes 3 kinds of engine displacement:

- T-rex 50 : 2 stroke engine (2T), 50cc displacement, abb. as "CP50".
- T-rex 110 : 2 stroke engine (2T), 110cc displacement, abb. as "CP110".
- T-rex125 : 4 stroke engine (4T), 125cc displacement, abb. as "CP125".
- T-rex150 : 4 stroke engine (4T), 150cc displacement, abb. as "CP150".

Please recognize your scooter model clearly in order to read the following instruments.

If there is any question, please do not hesitate to ask your dealer for assistance.

Check List before Delivery

Name : _____ Tel : _____ Age : _____ Sex : _____
 Address : _____
 Model : _____ Engine No : _____ VIN No : _____
 Delivery date : Year _____ Month _____ day _____ Dealer : _____

NO	Check Item	Y	N	NO	Check Item	Y	N
1	Steering of Handle Bar			7	Tire Pressure		
2	Gap of Brake Lever			8	Confirm Engine No & Document		
3	Lights and Horn			9	Owner's Manual		
4	Fuel Tank and Fuel Kind			10	Operating Method Introduction		
5	Engine Oil			11	Periodic Maintenance introduction		
6	Disk Brake fluid			12	Warranty Introduction		
Staff Signature : _____				Customer Signature : _____			

Suggestion :

- ※ Please Sign both customer & service Staff.
- ※ Mail this chart to agent, and then the Warranty will be effective.



PGO Warranty Card

Name		Telephone	Registration date
Address			
Model T-rex	Displacement: CC	Engine NO:	Vin NO:

Customer Signature

Dealer Signature

1.NOTATION FOR SAFETY RIDING

1.Please give certain signal during the situations as the following pictures:

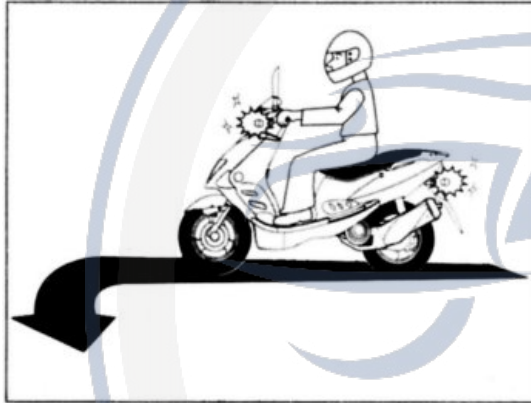

LEFT TURN



RIGHT TURN

Motorroller.de
- seit 1993 -

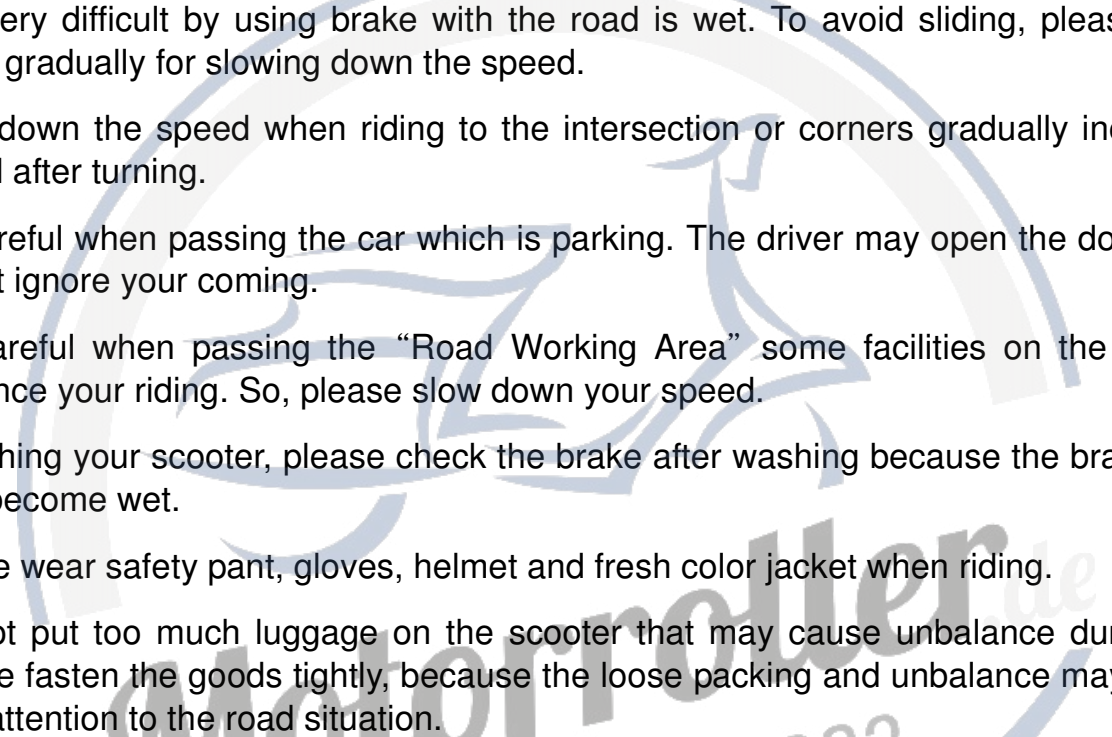
- 
- A large, light blue watermark logo for 'Motorroller' is centered on the page. It features a stylized scooter silhouette within a circular frame. Below the scooter, the text 'Motorroller' is written in a bold, sans-serif font, and below that, '- seit 1993 -' is written in a smaller font. The logo is semi-transparent, allowing the text of the list to be seen through it.
2. It is very difficult by using brake with the road is wet. To avoid sliding, please use the brake gradually for slowing down the speed.
 3. Slow down the speed when riding to the intersection or corners gradually increase the speed after turning.
 4. Be careful when passing the car which is parking. The driver may open the door and get off but ignore your coming.
 5. Be careful when passing the “Road Working Area” some facilities on the road may influence your riding. So, please slow down your speed.
 6. If washing your scooter, please check the brake after washing because the braking lining may become wet.
 7. Please wear safety pant, gloves, helmet and fresh color jacket when riding.
 8. Do not put too much luggage on the scooter that may cause unbalance during riding. Please fasten the goods tightly, because the loose packing and unbalance may influence your attention to the road situation.

2.OUTLINE CHARACTERISTICS:

Please read the indication no. carefully before using this scooter.

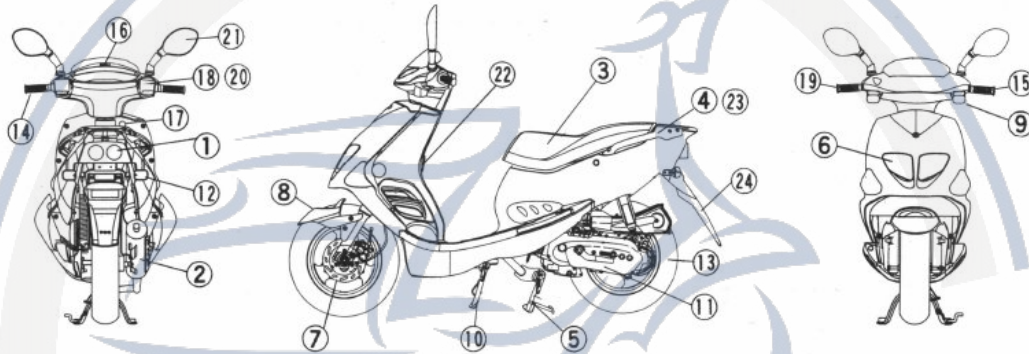

1. TAIL LAMP/BRAKE LAMP	13. REAR TIRE
2. MUFFLER	14. REAR BRAKE LEVER
3. SEAT	15. LEFT SWITCH
4. LUGGAGE COMP	16. SPEEDOMETER/CLOCK
5. CENTRAL STAND	17. MAIN SWITCH
6. HEAD LAMP	18. RIGHT SWITCH
7. FRONT TIRE	19. FRONT BRAKE LEVER
8. FRONT FENDER	20. THROTTLE GRIP
9. FRONT TURN SIGNAL LAMP	21. BACK MIRROR
10. SIDE STAND	22. HANGING HOOK
11. KICK STARTER	23. PASSENGER HOLDING BAR
12. REAR TURN SIGNAL LAMPS	24. SEPARATED MUDGUARD

3.RECOGNITION

1. Engine No. is located (stamped) on the rear side of the left crankcase.
2. VIN (Vehicle Identification Number) is located inside the front inner cover.

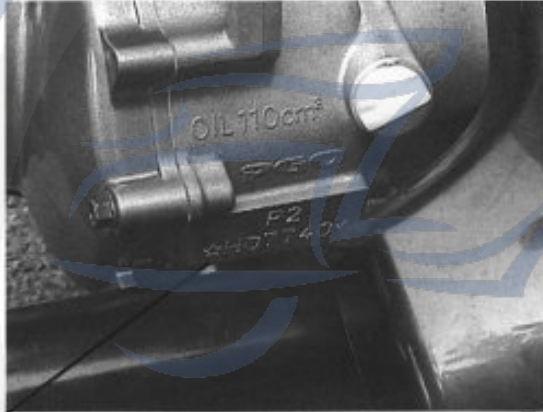

Engine No.



Vin No.

Note :

Your dealers need this number for ordering the parts, please write down the engine No. and VIN for their reference.

4. FUNCTION OF EACH CONTROLLER

MAIN SWITCH:

The main switch controlling the ignition and lighting - system the operation methods are shown on the following:

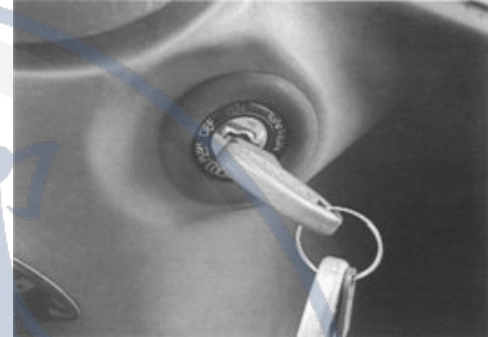

ON:

Electrical circuit is connected and engine can be started. At this moment, the key can't be pulled out.

OFF:

All electrical circuits are cut, at this moment, the key can be pulled out.

LOCK:

In this position, the handle comp. can be locked and key can be pulled out. Please refer to page 13 "Handle lock operation"

Note:

Please turn to "OFF" or "LOCK" (Pull out the key) location when park the scooter.

4.1 EACH INDICATOR LIGHT

- 1.Signal indicator
- 2.High beam indicator
- 3.Engine stop lamp
- 4.Clock
- 5.Oil warning lamp (only 2T model is available)

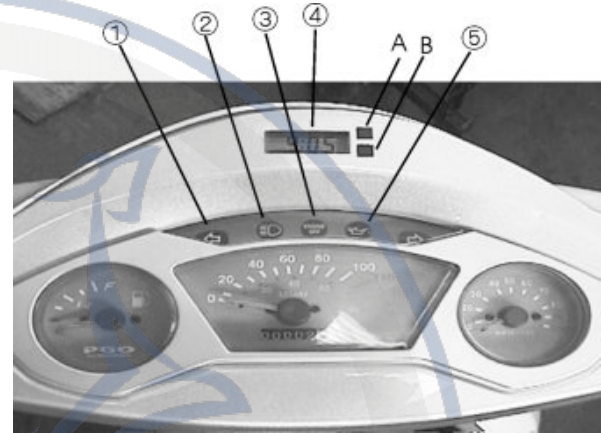

SIGNAL INDICATOR(GREEN) :

When operation, the lamp will flash with sound.

HIGH BEAM INDICATOR(BLUE) :

The engine start “≡D” lights indicating that the high beam is working.

ENGINE STOP LAMP(RED):

If the engine stop button switches to “OFF” ,the light will be “ON” then the electric circuit will be disconnected. the engine will be restarted, if the button switches to “RUN” .

CLOCK : (CURRENT TIME GENERALLY DISPLAYED)

Current date will be displayed while button “A” to be pressed. However, current time will be displayed automatically if the button “A” released over 2~3 second.

Current second will be displayed while button “A” to be pressed twice current time will be displayed if the button “A” to be pressed one time.

4.2 SPEEDOMETER

1. Fuel gauge
2. Mileage meters
3. Tachometer

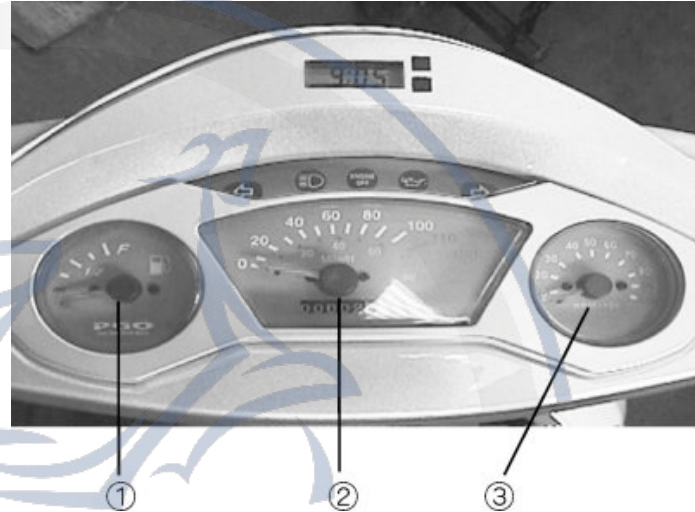

Fuel Gauge:

Indicate the volume of fuel in the tank. the indicator will move from “F” to “E” empty as the fuel is consuming. With the indicator point to the “Fuel Refill Line” ,Please refill fuel a.s.a.p.

Note :

When switch off, the indicator will point at the “E” Position.

Tachometer :

Tachometer : Indicates the engine rotating speed by rpm (round per minute).

4.3 HANDLE SWITCH



1. Hi/Lo Beam Switch
Turn to “≡D” for far distance lightening, “//D” for near distance.
2. Turn Signal Button
Left/Right turn: Turn the button to the left / right side. The button will return to central position automatically after pushing the button to “OFF” the signal.
3. Horn Button
Push the horn button, the sound will be heard.
4. Engine Off Switch
Engine will be forced to stop while switched to “OFF” position. Engine will be allowed to restart if switched to “RUN” position.
5. Start Button
Pull the break lever, and push the start button simultaneously, then the engine will be started.
6. Light Switch
Turn it to the first shift, the fog light will be “ON”. To the second shift, the head lamp & rear be “ON”.
7. Overtake Lamp
The lamp will blink after pushing the button.

4.4 FUEL TANK COVER

Plug the key into lock and turn it clockwise 1/4 round for cover opening.

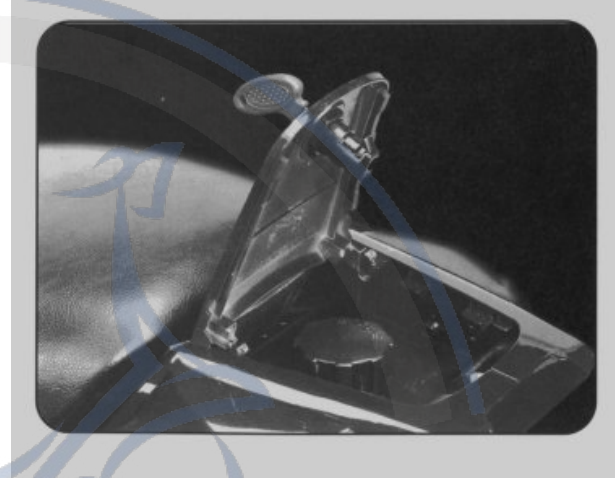

4.5 KICK STARTER

Pull the kick out from the engine (LH side) and kick down, then the engine will be started.(use kick starter for substituting to push the start button)

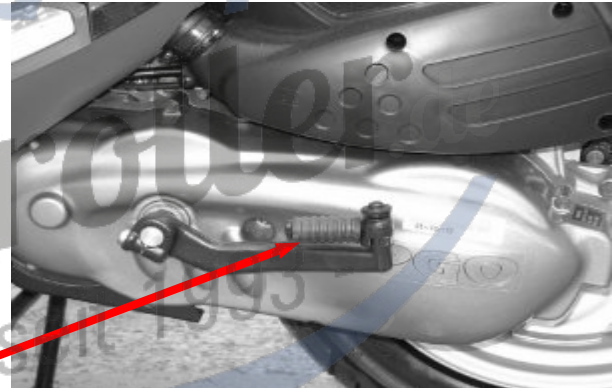

4.6 HANDLE(STEERING)LOCK

The first step-insert the key into the key hole. Second step - turn the handle bar to the left side and turn the key to the "LOCK" position simultaneously. The handle will be locked & the key can be pulled out.

Note:

Do not turn to lock position during riding.



4.7 SEAT LOCK

If need to open the seat, please insert the key and turn clockwise. Put back the seat to its original position for closing & locking. Please be sure the seat fastened before riding.



4.8 LUGGAGE COMP

Located under the seat. Put your helmet head upward.



Note:

1. The max. Loading weight is 5 Kgs.
2. If engine has been operating over a long time, The luggage comp. will become hot. Do not put luggage in the luggage comp. if dangerous for high temperature.
3. Do not put important or fragile goods for security.
4. Raining or wash may cause luggage wet inside. Please use water resistant material for luggage wrap.
5. Please lock the cover when leaving the scooter.

5. INSPECTION BEFORE RIDING :

PLEASE DO THE INSPECTION AS FOLLOWS BEFORE RIDING.

ITEM	PROCEDURE	RAGE
Front Brake	Check the brake function, clearance, brake oil level, see if it's leaking. If necessary, may refill FMVSS DOT 3 or SAE J1703 brake oil.	16 · 28
Rear Brake	Check the brake function and clearance, proper adjustment if necessary.	16 · 36
Throttle Grip	Check if it is smooth, put some lubricant & have some	19
Lubricant	Adjustments if necessary. Check the oil level/according to the request to refill oil.	19
Tire	Check the pressure, the wear out situation.	20
Controller /Gauge Cable	Check if smooth operation. Add lubricant if necessary.	-
Central Stand	Check if smooth. Add lubricant if necessary.	-
Assembly/ Fasten Fits	Check all the assembling parts, fixing & adjusting if necessary.	-
Fuel Tank	Check the fuel level. Refill up if necessary.	12
Lamp/Signal Lights	Check if it is operating at good condition.	11

5.1 REAR AND FRONT BRAKE LEVER

Hold the handle and pull the lever, the brake will be operating.

Rear Brake Lever

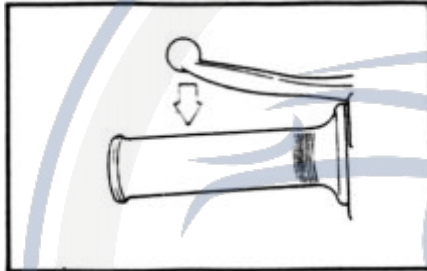

The rear brake will be on function when hold the handle and pull the left hand lever

Front Brake Lever

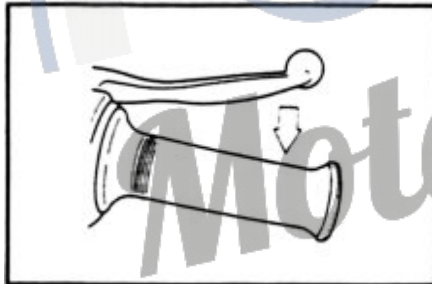

The front brake will be on function when hold the handle and pull the right hand lever

5.2 BRAKE (REF. PAGE 36)

1. Front & Rear Brake Lever:

You may check the brake during the low speed riding. Check the clearance, if not correct, please adjust.

Note: If the lever is loose, that means the brake system is out of order (It is dangerous).

Do not ride it before fixing.

2. Brake Oil:

Check the oil level, refill brake oil if necessary. (Using FMVSS DOT 3 or SAE J1703 brake oil).

3. Pad Of Disk Brake:

Take your scooter to your dealers if need to replace the brake pad.

5.3 BRAKE OIL LEAKING CHECK

Holding brake lever for few minutes and check if any oil is leaking from the joint of brake tube or master cylinder.

Note: If the brake oil is leaking, Please let your dealers check it for you. (It is a dangerous situation)

5.4 OUR SUGGESTION

1. The inspection should be proceeded before every riding. Don't be indolent to execute such inspection.
2. Pleas try to fix it to good condition or carry it to your dealers for help, if any abnormal symptom is detected.

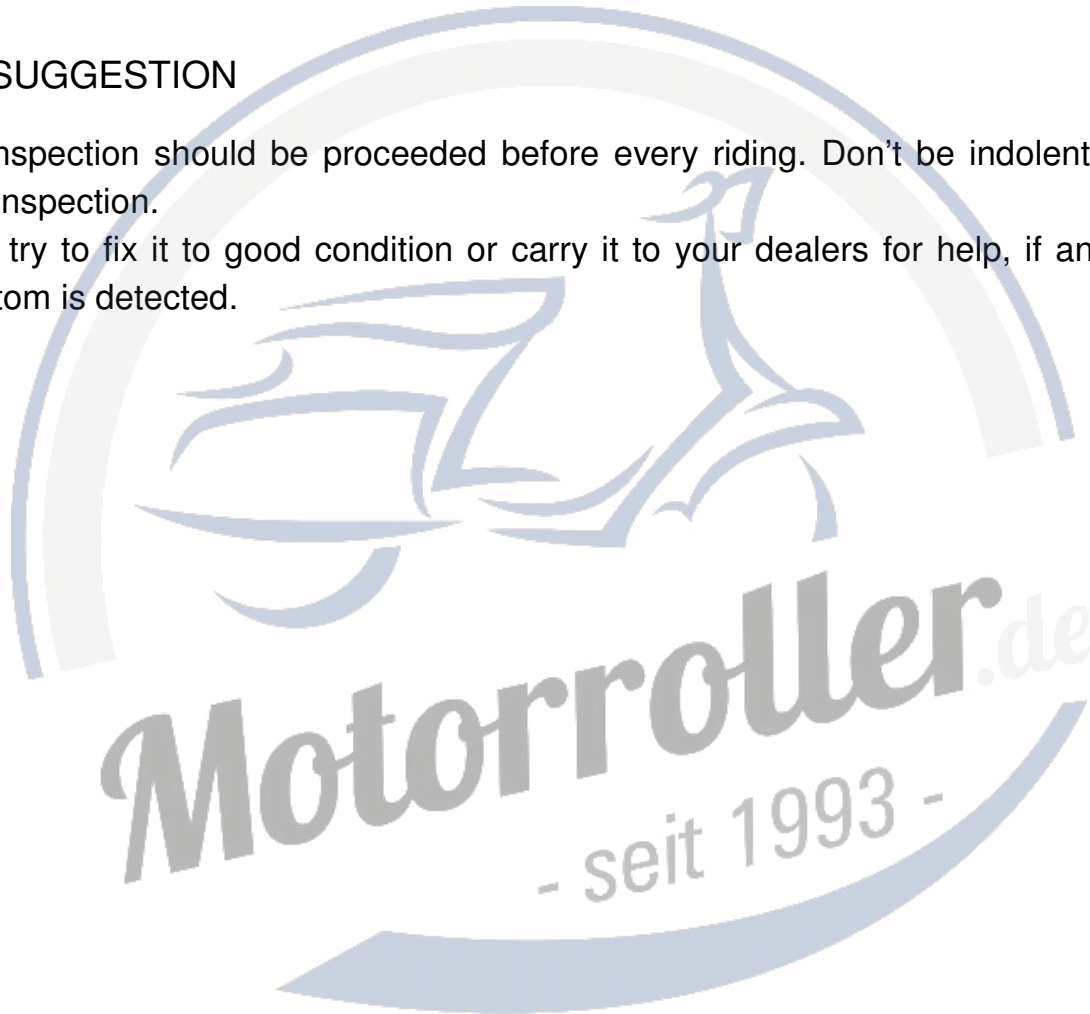

5.5 THROTTLE GRIP

Turn the grip and check the clearance & operation situation. Make sure the grip will automatically return to the original position. Ask your dealers for adjusting if necessary.

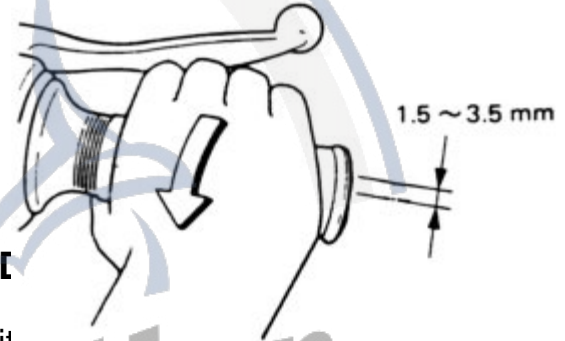

5.6 LUBRICANT: (ONLY AVAILABLE FOR 2T MOI)

Keep the lubricant be full. Capacity of lubricant: 1.1 liter.

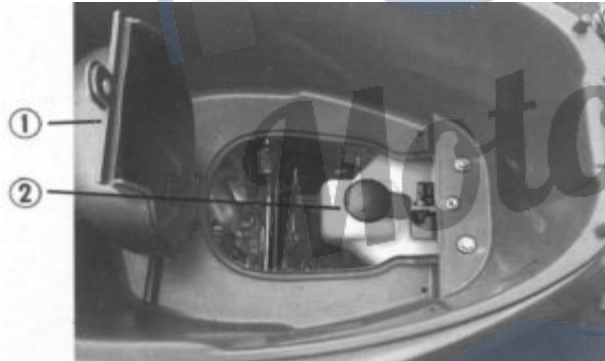

1. Luggage low cover
2. Lubricant case cap

Note: If do not use the certain lubricant (which we recommended) that may cause high density emission.

5.7 AIR-CLEANER

The air filter will keep dust away from the engine and also protect it against wearing out. Please ask the dealers to check & clean the filter periodically , or by yourself. (ref : page 33,34)

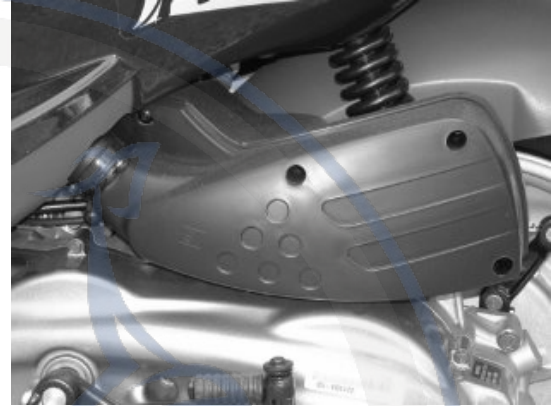

5.8 TIRE

To secure the best performance & extend life-span , please pay your attention to the following.

1. TIRE PRESSURE

Be sure tire pressure in accordance with the standard pressure.

Note:

The inside temperature of tire must be even to outside if pressure Needs to be adjusted besides. The factor of loading, weight even Cruising speed should take into consideration before adjusting.

The normal tire pressure:

Front : 2.0 kg/cm square

Rear : 2.0 kg/cm square



a. Tire pressure too high.



b. Tire pressure too low.

2. SIMPLE CHECK :

Check the appearance before riding. Please ask your dealers for Repairing or replacing if the appearance has been detected significant Worn out or stabbed by nails, or glass.



3. INSPECTION FOR THE DEPTH OF THE TIRE GROOVE :

The appearance will become slippery due to significant worn out, dusty or wet road riding. Please replace the tire if the depth is less than 0.8mm, see the following picture for reference.



Note :

1. It is very dangerous to ride a scooter with a wearing out tire, if the depth of tire decreases to the indicator arrow. Please ask your dealer to change a new tire for you.
2. Used tire should not be applied besides, don't repair brakes, tire or replace parts by yourself. Your dealers will provide a professional service for you.



5.9 LAMPS & SIGNAL LIGHTS

Make sure the head lamp, brake lamp, turn signal lamp, tail lamp and all others indicator lights working well.

5.10 SWITCHES

Make sure the switches of head lamp, turn signal lamp, brake lamp, horn, start button, and overtake lamp working well.

5.11 FUEL

Be sure sufficient gas in the tank.

Tank capacity : 6.7 L

Note :

1. Please fill the unleaded gas if your scooter is equipped with catalyzer.
2. Do not fill up the gas over the neck of gas entrance, otherwise it will be spilling out due to the hot temperature.
3. It may cause inflammable if gas is split onto the engine or muffler.

5.12 CATALYSTER (OPTION DEVICE)

Catalyst device is designed for decreasing air pollution from exhaust system and it is mounted inside the muffler.



Note:

1. Make sure park your tricycle away from flammable material, pedestrian or child to avoid danger due to yielding hot from muffler cover.
2. Don't try to use any fuel if it is not unleaded gas.
3. Don't try to turn off the main switch when riding.
4. Don't try to ride idle or stop on the surface of inflammable.
5. Please keep your engine in good function all the time, otherwise high temperature will yield from catalyst device due to circuit, ignition or fuel system abnormally working.
6. Please periodically maintain your scooter to ensure exhaust control system and catalyst device working well.

6. NOTATION FOR OPERATION & RIDING

1. Please make sure you are familiar with all the operation system function before riding. Please contact with your dealers if the any question.
2. Do not start the engine in a closed place due to potential threat form poisonous exhaust amassed.

6.1 STARTING ENGINE

1. Be sure to turn the switch of engine stop to “ run “ , then turn main switch to “ on “ .
2. When the throttle is totally loosed, hold the brake lever & the starter button or use the kickstarter to start the engine.



Note :

If the engine can't be started. You should loose the starter button avoid losing significant electric power. Please do not push the button over 5 seconds per each time. Try kicks starter to start the engine if the start button is not working properly.

6.2 WARM UP THE ENGINE

To protect the engine, please warm up the engine 1~3 minutes before riding. Do not immediately accelerate when engine is cold.

Note :

Please read the instruction “ engine initial run-in “ page 29 before initial riding.



SCOOTER RIDING (AFTER WARM UP THE ENGINE) :

- (1) Hold the brake lever and push down the central stand.
- (2) Adjust the angle of rear view mirrors within visible field.
- (3) Try the function of signal light before riding.
- (4) Turn the throttle grip gradually then close the signal light during riding

ACCELERATING (THROTTLING) :

Use the throttle grip control your cruise turning it toward your side will speed up, and reversing it will slow down.

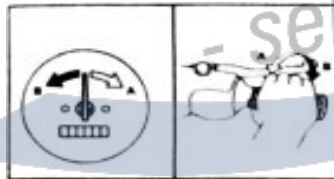

6.3 BRAKE OPERATION

1. Release the throttle grip.
2. Press the lever of front and rear brake gradually.

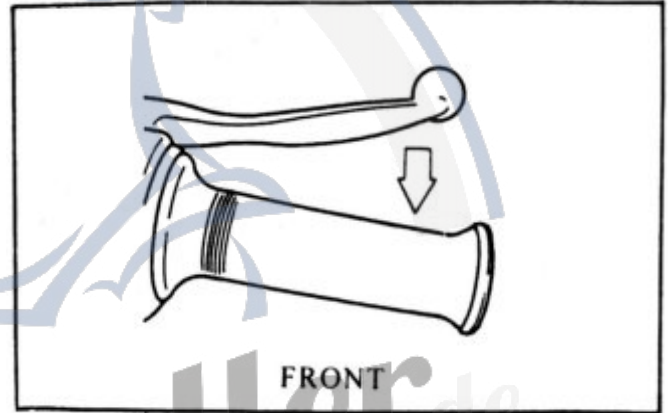
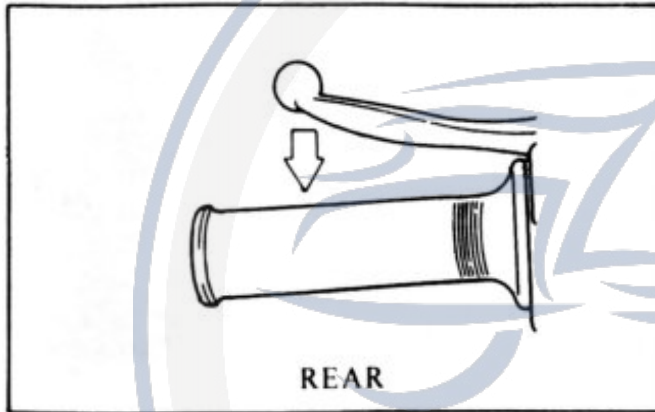

Note :

1. Sudden stop will cause sliding even falling down turning.
2. Use the braking carefully while you are turning. Improper using the brake may cause sliding.
3. Slow down the speed when riding on the iron plate, Rail way track, wet road.
4. Braking on the wet road is difficult.
5. Slow down the speed when sloping down.

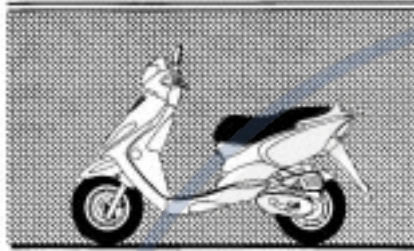

CORRECT

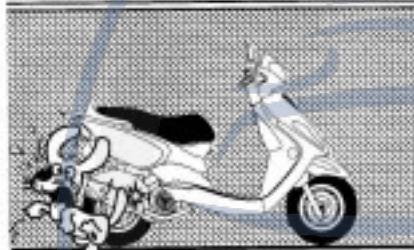

INCORRECT



INCORRECT

PARKING:

Turn off the engine and pull out the key when parking the scooter.

NOTE:

Please park your scooter away from the child & pedestrians if the muffler is hot. do not park your scooter on a slop or soft ground to avoid falling down.

6.4 ENGINING INITIAL RUN-IN

1 ~ 1,000 kms riding will be the critical period regarding scooter life span. The new engine can't afford too much loading during the first 1,000 kms. Every part of the engine will be run-in to obtain the correct clearance in this period. Be sure to avoid prolonging the correct out totally or any operation causing high temperature in the engine. Please read careful the following information.

1. 0 ~150 kms

Avoid over 1/2 throttling operation. Cool down the engine 5 ~ 10 min/ hour. Do not cruised by constant speed for riding.

2. 150 ~500 kms

Avoid over 1/2 throttling operation for long distance riding.

3. 500~1,000 kms

Avoid over 3/4 throttling operation.

Note :

Change gear & engine oil after 300 kms.

4. Over 1,000 kms

Avoid full throttling in a long distance riding.

Note :

Please contact your dealers if any problem takes place during above periods

7. PERIODICAL MAINTENANCE

To secure the most safe & effective performance, Please check, adjust, and lubricate your scooter periodically. Periodical maintenance and lubrication should be acknowledged as a important instruction. meanwhile, Please pay your attention to the environment, climate, geography and riding status in order to set up a proper maintenance interval.

Note :

This scooter is designed to be riding on normal paved road. If under a dirt & wet condition, please clean the air-cleaner frequently, otherwise the engine will be worn out quickly.

If you are not familiar with the inspection & maintenance. Please contact to your dealers.

Motorroller.de
- seit 1993 -

**Maintenance table(A:checking & adjusting, C:cleaning, R:replacing, T:tightening:)
Available for 2T model**

Item	Driving Kilometers													Examine before Driving
	300	1000	2000	3000	4000	5000	6000	7000	8000	9000	10000	11000	12000	
Spark plug	Clean it once per 3,000kms or chang a new one													
Decarbonizing							C						C	
Transmission belt							A						A	
Ignition timing							A						A	
Air cleaner				C			C			C			C	
Carburetor	A			A			A			A			A	
Idle(rpm)	Tuning to 1,900 ± 100rpm													
Emission	A			A			A			A			A	
Fuel filter							C						C	
Oil filter							C						C	
Oil volume	Refill the recommended oil. Once the “warning lamp”flashing													
Gear oil	R						R						R	
Pressure of tyre	A			A			A			A			A	A
Tyre	Change a new one once wearing out													A
Barke lever	A			A			A			A			A	A
Disk brake oil	Keep the liquid surface between high and low													A
Brake lining	Checking per 6,000kms and change a new one if necessary													
Screws and nuts	T			T			T			T			T	
Pipes	A			C			C			C			C	
Light & horn	A			A			A			A			A	A

**Maintenance table(A:checking & adjusting, C:cleaning, R:replacing, T:tightening:)
Available for 4T model**

Item	Driving Kilometers													Examine before Driving
	300	1000	2000	3000	4000	5000	6000	7000	8000	9000	10000	11000	12000	
Spark plug	Clean it once per 3,000kms or chang a new one													
Valve clearance						A					A			
Transmission belt						A					A			
Ignition timing						A					A			
Air cleaner				C		C			C		C			
Carburetor	A			A		A			A		A			
Idle(rpm)	Tuning to 1,700 ± 100rpm													
Emission	A			A		A			A		A			
Fuel filter						C					C			
2 nd Oil filter						R					R			
Oil replacement	Replace it per 1,000 kms													
Gear oil	R					R					R			
Pressure of tyre	A			A		A		A		A				A
Tyre	Change a new one once wearing out													A
Barke lever	A			A		A		A		A				A
Disk brake oil	Keep the liquid surface between high and low													A
Brake lining	Checking per 5,000kms and change a new one if necessary													
Screws and nuts	T			T		T		T		T		T		
Pipes	A			C		C		C		C		C		
Light & horn	A			A		A		A		A		A		A

7.1 THE AIR-CLEANER CHECK

A. 2T sponge model

1. Loosen screws then remove.
2. Take off the cover of filter.
3. Draw the sponge of filter.
- 4 Wash, squeeze, spray some oil and squeeze again referring to figure.
5. Put the cover back carefully to make sure fitted to the cover without crack.

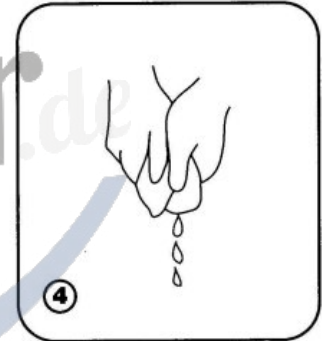

7.1 THE AIR-CLEANER CHECK

B. 2T paper & 4T model

1. Loosen screws then remove.
2. Take off the cover of filter.
3. Draw the core of filter.
4. Clean and dry by air compressor.
5. Put the cover back carefully to make sure fitted to the cover without crack.

**2T Paper
model**

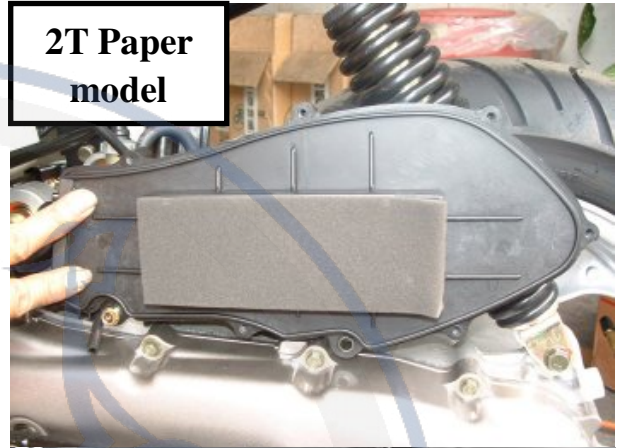

**4T Paper
model**

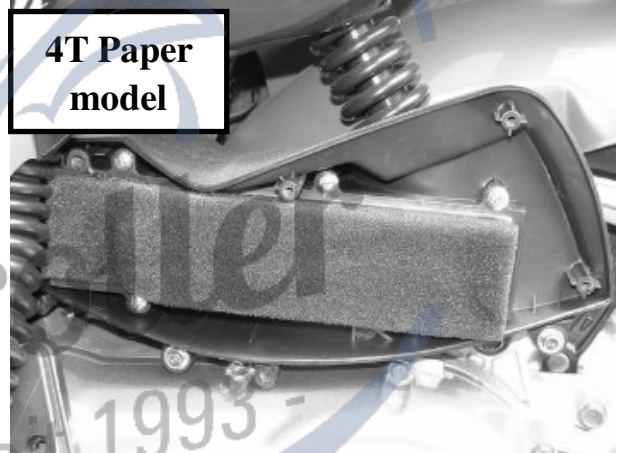

Note :

Please do not start the engine before the air-cleaner is assembled, otherwise the engine will be badly worn out.

7.2 THE SPARK PLUG CHECK

Spark plug is one of the important parts of the engine and it is easy to be checked. According to spark plug condition. You may infer the situation of the engine. The ideal color of the electrode should be light brown. If there's any problem, please ask your dealers to check for you. Please take off the spark plug after a period of time because it will be corroded & worn out due to the hotness and dirt for the time being. If happened, please change a new spark plug.

- Standard spark plug: 2T engine: BP7HS(NGK) or BPR7HS for EEC regulation
4T engine: C7HSA(NGK) or CR7HSA for EEC regulation
- Spark plug gap:0.6~0.7mm

When checking the spark plug, please cleaning the surface of the washer and screw, then fasten it.

- Torque: 2.0 kgf-m

Note:

If there is no wrench w/torque gauge can be used, please wrenching it by your fingers turn 1/4~1/2 and later use the wrench to fix it to the standard torque once available.

7.3 BRAKE ADJUSTMENT

The clearance of lever

(a) Front brake: 5~7mm

(b) Rear brakes: 10~20mm

Note:

Please contact to PGO dealer if the clearance is incorrect.

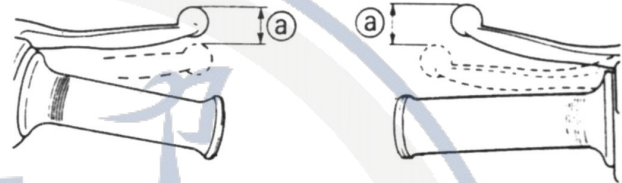

7.4 REAR BRAKE CHECK

Check the brake efficiency usually , adjust the free play by the nuts shown.

2T Model



4T Mode



7.5 FRONT BRAKE CHECK

If the indicator almost reach the disk, Please ask your dealers to change it.

- 1.Brake Disk
- 2.Caliper (brake pad inside)
- 3.Brake hose

Note:please be sure to put the cover back and fasten. If the brake area is wet(getting water), the brake will be out of order and get dangerous to you.

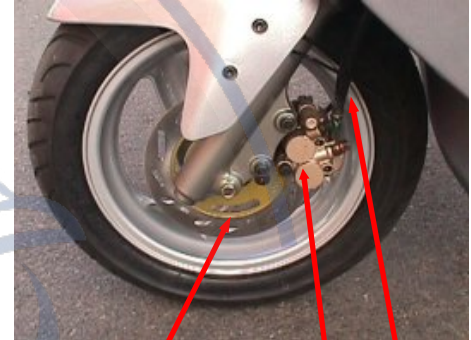

1 2 3

7.6 BRAKE OIL CHECK

Insufficient brake oil will make the air into the brake system and may cause the brake out of control. Please check the brake oil level all the time and refill it if necessary.

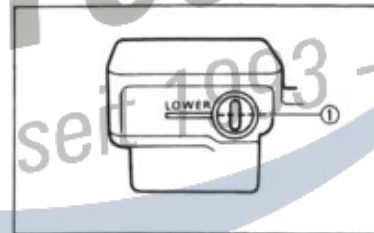

1. LOWER LEVEL

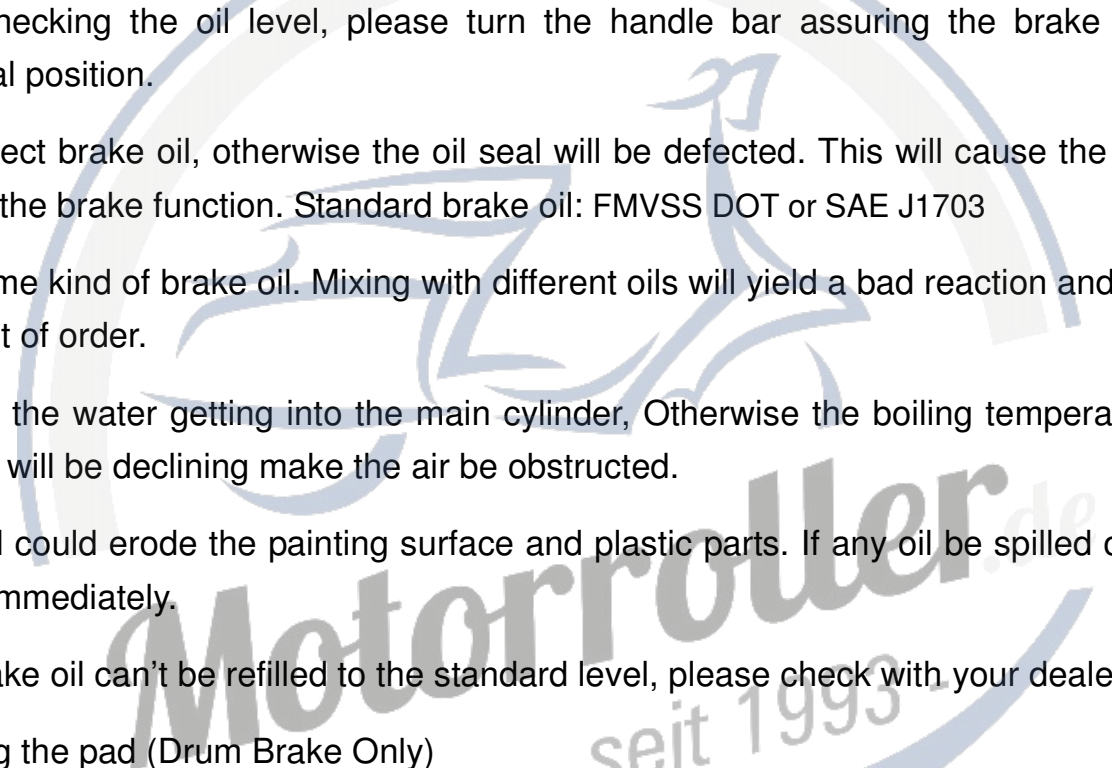
- 
- A large, light blue watermark logo for Motorroller is centered on the page. It features a stylized roller with a curved arrow pointing upwards and to the right. Below the roller, the text 'Motorroller' is written in a bold, sans-serif font, and below that, '- seit 1993 -' is written in a smaller font. The entire logo is enclosed within a circular border.
1. When checking the oil level, please turn the handle bar assuring the brake oil on the horizontal position.
 2. Use correct brake oil, otherwise the oil seal will be defected. This will cause the oil leaking & losing the brake function. Standard brake oil: FMVSS DOT or SAE J1703
 3. Refill same kind of brake oil. Mixing with different oils will yield a bad reaction and cause the brake out of order.
 4. To avoid the water getting into the main cylinder, Otherwise the boiling temperature of the brake oil will be declining make the air be obstructed.
 5. Brake oil could erode the painting surface and plastic parts. If any oil be spilled out, please clean it immediately.
 6. If the brake oil can't be refilled to the standard level, please check with your dealers.
 7. Checking the pad (Drum Brake Only)

7.7 FRONT FORK CHECK

Note:

In order to avoid falling down, please park your scooter firmly will be safe.

1.Eyes Checking:

If any scratched, broken or leaking inside the pipe by vision.

2.Operating check:

Park the scooter on flat place.

(a)Hold the handle and keep the scooter in vertical position, and then hold the front brake lever.

(b)Move up & down the front fork for several times.

Note:

If found the front fork is not smooth or broken, please contact your dealers.



Eyes check

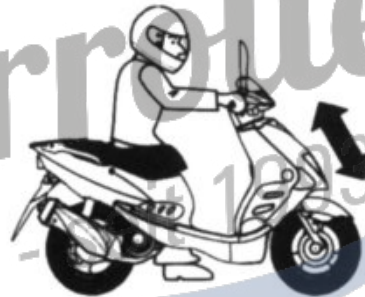

Function check

7.8 BATTERY

The battery is in free- maintenance type, so it won't be necessary to check or refill the liquid. If the liquid is leaking, please contact with your dealers A.S.A.P.

Note:

Please do not try to take off the sealed bolt, that will damage your battery.



Note:

Do not use a higher ampere fuse than the standard one. A different (abnormal) fuse will damage circuit system and may cause fire.

7.9 FUSE REPLACEMENT

- 1.The fuse is located beside the battery.
- 2.Take off front cover by loosening two screws.
- 3.If the fuse is burned out, turn off the main switch and related switches. Replace a correct fuse, then turn on and check the circuit function. Please contact with your dealers if the problem remains.

7.10. GEAR OIL REPLACEMENT

- Please change the oil after first 300km ride, then it is recommended to change the gear oil every 2000 ~ 3000km.
- Regular changing volume : 90 c.c. (SAE 140)



8.1 SPEC. LIST

Type	CP-50	CP-110
Dimension:		
Overall Length	1890mm	1890mm
Overall Width	696mm	696mm
Overall Height	1145mm	1145mm
Seat Height	770mm	770mm
Wheel base	1275mm	1284mm
Vehicle Dry Weight	99 kg	102 kg
Engine:		
Type	2 stroke, forced air cooling	2 stroke, forced air cooling
Model No.	P2	P0
Cylinder Array	Single	Single
Piston Displacement	49 cm ³	106.2 cm ³
Start System	Electric and kick	Electric and kick
Lubrication System	Separate	Separate
Lubricant	Recommend two stroke oil	Recommend two stroke oil
Capacity	1.1 L	1.1 L

Type	CP-50	CP-110
Gear Oil: Model Reduction Gear: Replacement Total	SAE 140 90cc 110cc	SAE 140 90cc 110cc
Air Cleaner	Dry Filter or Sponge	Dry Filter or Sponge
Fuel: Gasoline Capacity of tank	(premium or unlead for the one equipped catalyser) 6.7L	(premium or unlead for the one equipped catalyser) 6.7L
Spark Plug	BP7HS(NGK)or L82YC(Champion)	BP7HS(NGK)or L82YC(Champion)
Clutch Type	Dry Type	Dry Type
Gear Shift Type	Automatic(V Belt)	Automatic(V Belt)
Tire: Size(Front) (Rear)	120/70-12 X 1 130/70-12 X 1	120/70-12 X 1 130/70-12 X 1
Electric System Ignition System Generator System Battery Type Capacity Of Battery	C.D.I. Fly wheel Magnet Electric YT4L-BS 12V 3AH	C.D.I. Fly wheel Magnet Electric YT5L-BS 12V 4AH

8.2 SPEC. LIST

Type	CP-125	CP-150
Dimension:		
Overall Length	1890 mm	1890 mm
Overall Width	696 mm	696 mm
Overall Height	1145 mm	1125 mm
Seat Height	770 mm	770 mm
Wheel base	1284 mm	1284 mm
Dry Weight	108 kg	116 kg
Engine:		
Type	4 stroke, forced air cooling	4 stroke, forced air & oil cooling
Model No.	C1	C5
Cylinder Array	Single	Single
Piston Displacement	124.9 cm ³	147.5 cm ³ ; 150.1 cm ³ for specified area
Start System	Electric and kick	Electric and kick
Lubrication System	Pump & Splash	Pump & Splash
Lubricant	Recommend 15W40	Recommend 15W40
Capacity	0.9L	0.9L

Type	CP-125	CP-150
Gear Oil: Model Reduction Gear: Replacement Total	SAE 140 90cc 110cc	SAE 140 90cc 110cc
Air Cleaner	Wet Paper Filter	Wet Paper Filter
Fuel: Gasoline Capacity of tank	(premium or unlead for the one equipped catalyser) 6.7L	(premium or unlead for the one equipped catalyser) 6.7L
Spark Plug	C7HSA(NGK)	C7HSA(NGK)
Clutch Type	Dry Type	Dry Type
Gear Shift Type	Automatic(V Belt)	Automatic(V Belt)
Tire: Size(Front) (Rear)	120/70-12 X 1 130/70-12 X 1	120/70-12 X 1 130/70-12 X 1
Electric System Ignition System Generator System Battery Type Capacity Of Battery	C.D.I. Fly wheel Magnet Electric YT7L-BS 12V 6AH	C.D.I. Fly wheel Magnet Electric YT7L-BS 12V 6AH

Appendix:

Periodic Maintenance Record

Plan km	Actual km	Date	Dealer Sign.	Plan km	Actual km	Date	Dealer Sign.
300				14,000			
1,000				15,000			
2,000				16,000			
3,000				17,000			
4,000				18,000			
5,000				19,000			
6,000				20,000			
7,000				21,000			
8,000				22,000			
9,000				23,000			
10,000				24,000			
11,000				25,000			
12,000				26,000			
13,000				27,000			

- Please decrease maintenance period when often driving in dusty areas.
- Copy the blank table to use when odometers is over the above table planned.