

Spaß und Sparen



Eppella fahren

Teilebuch



AEON

Overland 180

Motorroller.de
- seit 1993 -

Friedrich Epple GmbH
Im Erlengrund 1
64678 Lindenfels, OT Eulsbach
Tel.: 06255 30030
E-Mail: info@motorroller.de
Web: www.motorroller.de

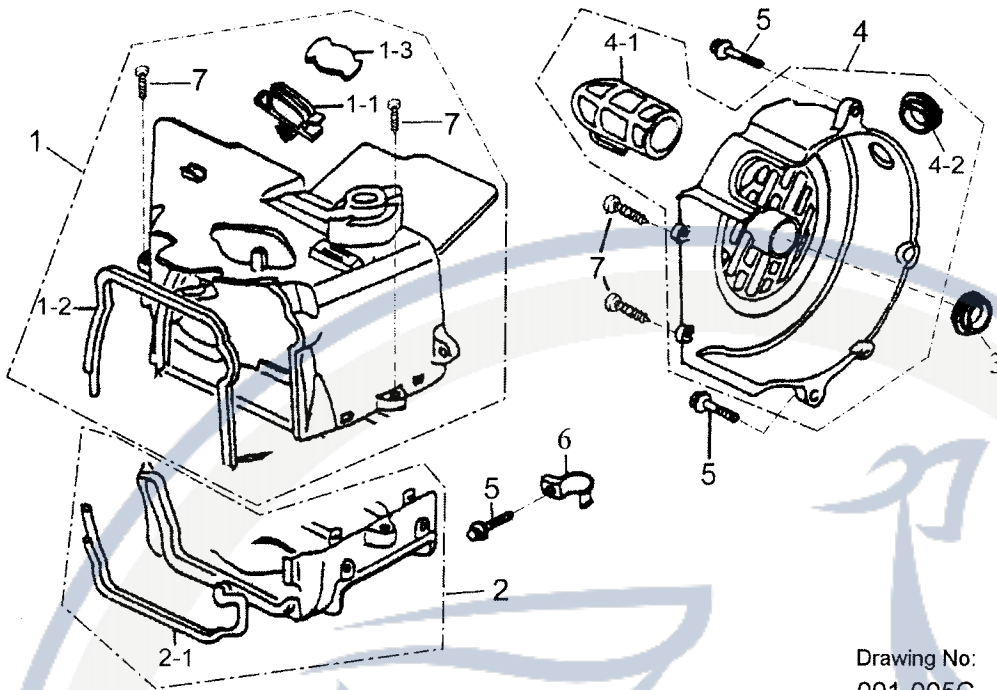

Drawing No:
001-005C

P/N	DESCRIPTION	PART NO.	Q'TY	REMARK
1-1	SHROUD - UPPER	19623-119-000	1	
1-1-1	BREATHER TUBE CLAMPER	11384-119-000	1	
1-1-2	SHROUD SEAL UPPER	19635-119-000	1	
1-1-3	RUBBER BUNG B	19633-119-000	1	
1-2	SHROUD -LOWER	19621-119-000	1	
1-2-1	SHROUD SEAL-LOWER	19625-119-000	1	
1-3	RUBBER CAP	19611-156-000	1	
1-4	FAN COVER ASS'Y	19610-119-001	1	
1-4-1	CARBURETOR COOLING DUCT	19615201-000	1	
1-4-2	RUBBER BUNG	17529-119-000	1	
1-5	HEX FLANGE	96000-06025-8C	3	M6x25
1-6	CLAMPER CARB DRAIN TUBE	11353-119-000	1	
1-7	CROSS TAPPING SCREW	93904-05016-K	4	5x16

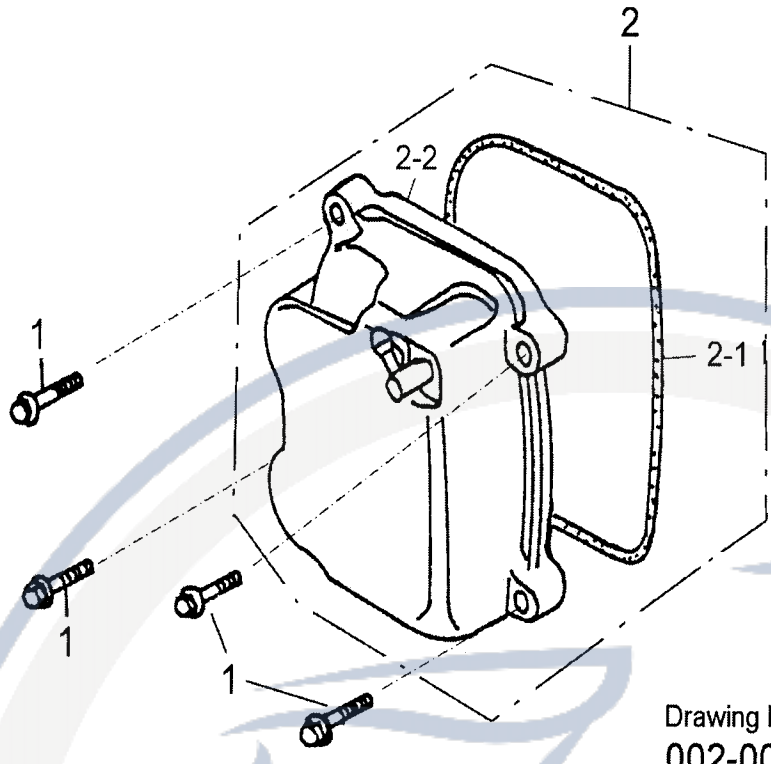

Drawing No:
002-000

P/N	DESCRIPTION	PART NO.	Q'TY	REMARK
2-1	HEX FLANGE BOLT	96000-06025-8C	4	M6x25
2-2	CYLINDER HEAD COVER ASS'Y	12310-158-000	1	
2-2-1	CYLINDER HEAD COVER GASKET	12391-119-000	1	
2-2-2	CYLINDER HEAD COVER	12309-158-000	1	

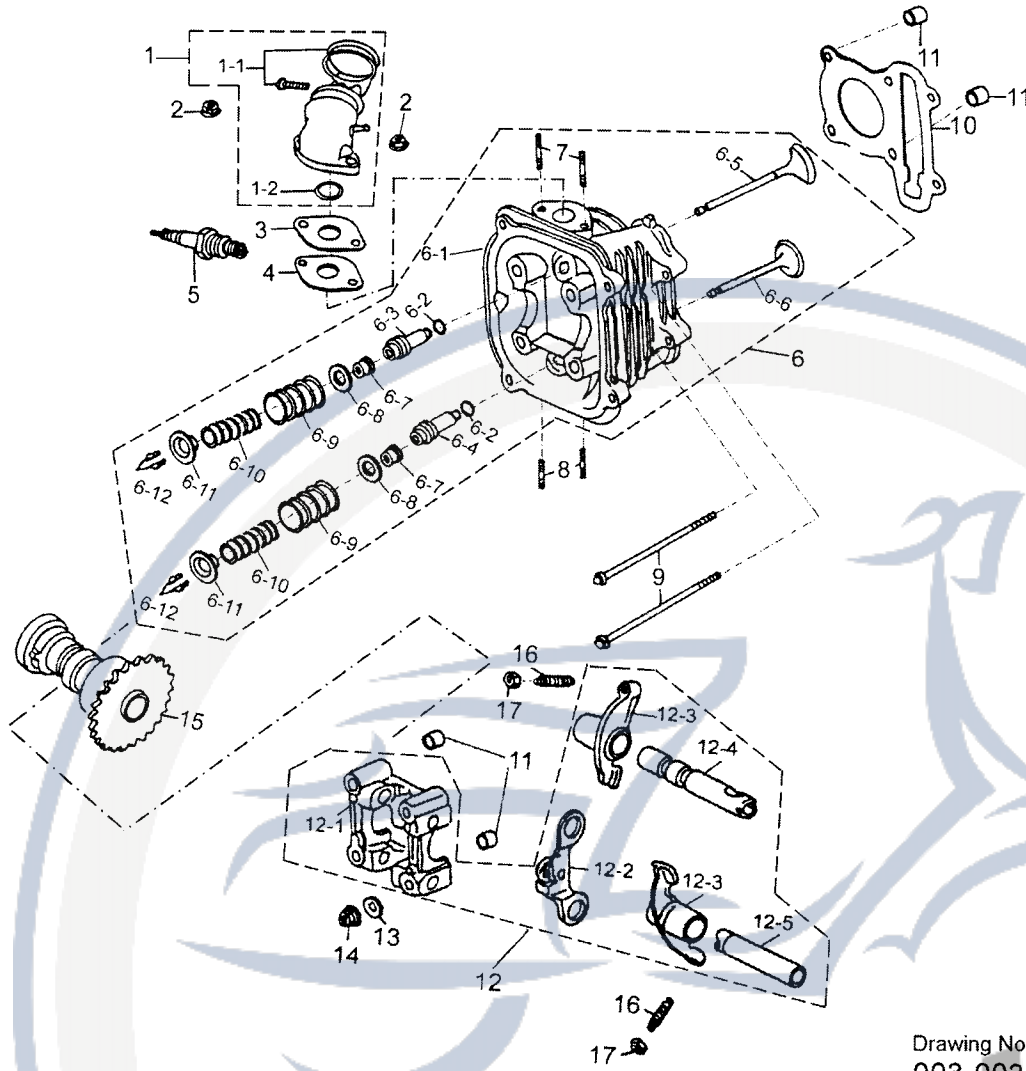

Drawing No:
003-003

P/N	DESCRIPTION	PART NO.	Q'TY	REMARK
3-1	INAKE MAINFOLD	17100-179-000	1	
3-1-1	BAND INSULATOR	14111-119-000	1	
3-1-2	OIL-RING	91327-119-000	1	27x2
3-2	HEX FLANGE NUT	94050-06000-C	2	M6
3-3	CARBURETOR INSULATOR	16213-119-000	1	
3-4	CARBURETOR INSULATOR GASKET	16229-119-000	1	
3-5	SPARK PLUG(ANTI-RESISTANCE)	98076-119-00A	1	CR7HSA

3-6	CYLINDER HEAD ASS'Y	12200-158-000	1	
3-6-1	CYLINDER HEAD	12201-158-000	1	
3-6-2	OIL-RING	91309-119-000	2	9.5x1.5
3-6-3	IN.GUIDE VALVE	12204-119-000	1	
3-6-4	EX.GUIDE VALVE	12206-119-000	1	
3-6-5	IN. VALVE	14711-122-000	1	
3-6-6	EX. VALVE	14721-122-000	1	
3-6-7	VALVE STEM SEAL	12209-119-000	2	
3-6-8	SEAT VALVE SPRING OUTER	14775-119-000	2	

15.11.2004

3-6-9	VALVE OUTER SPRING	14751-119-000	2	
3-6-10	VALVE INNER SPRING	14761-119-000	2	
3-6-11	VALVE SPRING RETAINER	14771-119-000	2	
3-6-12	COTTER VALVE	14781-119-000	4	
3-7	STUD BOLT	91001-06072-C	2	M6x72
3-8	STUD BOLT	91001-08032-C	2	M8x32
3-9	HEX FLANGE BOLT	96000-06100-8C	2	M6x100
3-10	CYLINDER HEAD GASKET	12251-158-000	1	
3-11	DOWEL PIN	94301-10140	4	10x14
3-12	CAM SHAFT HOLDER ASS'Y	12210-158-000	1	
3-12-1	CAMSHAFT HOLDER	12211-158-000	1	
3-12-2	PLATE COMP STOPPER	14456-119-000	1	
3-12-3	ARM VALVE ROCKER	14431-119-000	2	
3-12-4	SHAFT COMP IN ROCKER ARM	14452-158-000	1	
3-12-5	SHAFT EX ROCKER ARM	14453-158-000	1	
3-13	COPPER PLAIN WASHER	94101-0818023-U	4	8x18x2.3
3-14	HEX FLANGE NUT	94050-08000-C	4	M8
3-15	CAMSHAFT COMP	14400-122-000	1	
3-16	SCREW TAPPEL ADJUSTING	90012-119-000	2	
3-17	TAPPET ADJUSTING	90206-119-000	2	

Motorroller.de
- seit 1993 -

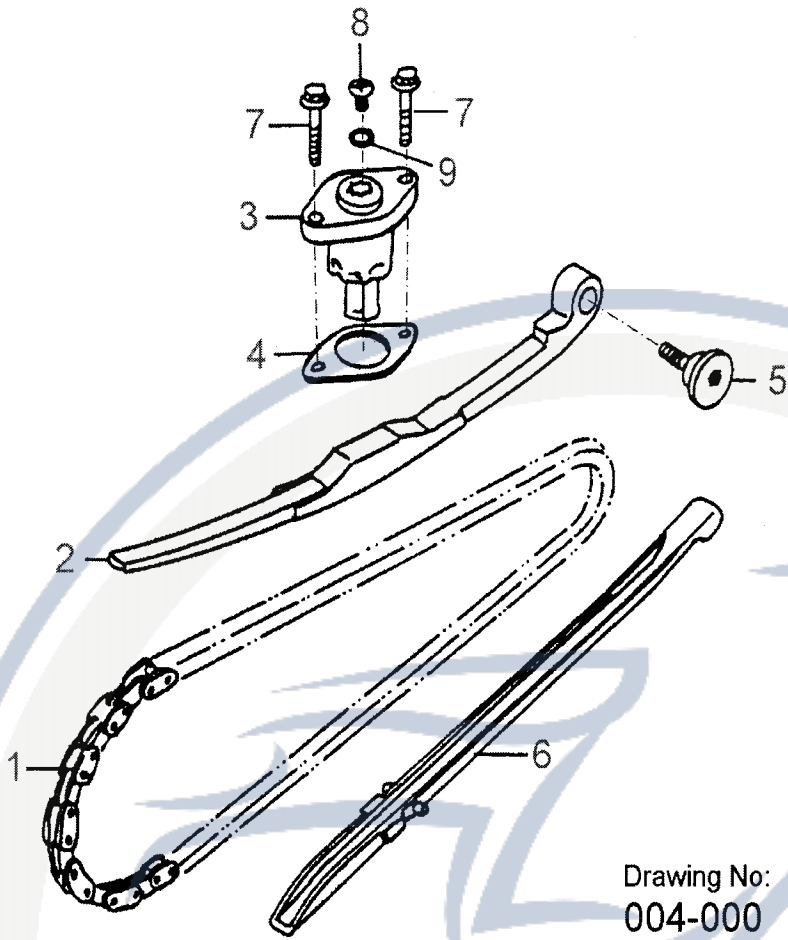

Drawing No:
004-000

P/N	DESCRIPTION	PART NO.	Q'TY	REMARK
4-1	CHAIN CAM	14401-119-000	1	
4-2	TENSIONER CAM CHAIN	14550-119-000	1	
4-3	LIFTER TENSIONER LIFTER	14521-119-000	1	
4-4	GASKET TENSIONER LIFTER	14523-119-000	1	
4-5	PIVOT CAM CHAIN TENSIONER	14535-119-000	1	M6x22
4-6	GUIDE COMP CAM CHAIN	14500-119-000	1	
4-7	HEX FLANGE BOLT	96000-06022-814C	2	M6x22
4-8	SCREW,PAN	93000-06006-K	1	M6x6
4-9	OIL-RING	91309-119-000	1	9.5x1.5

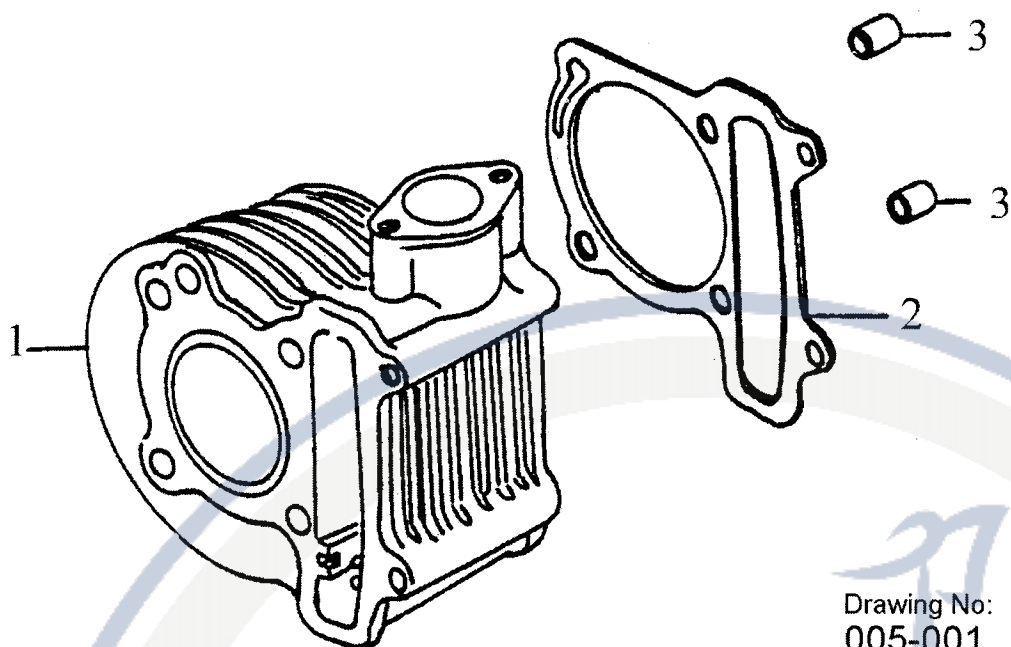

Drawing No:
005-001

P/N	DESCRIPTION	PART NO.	Q'TY	REMARK
5-1	CYLINDER	12101-158-001	1	
5-2	CYLINDER GASKET	12191-158-000	1	
5-3	DOWEL PIN	94301-10140	2	10x14

Motorroller.de
- seit 1993 -

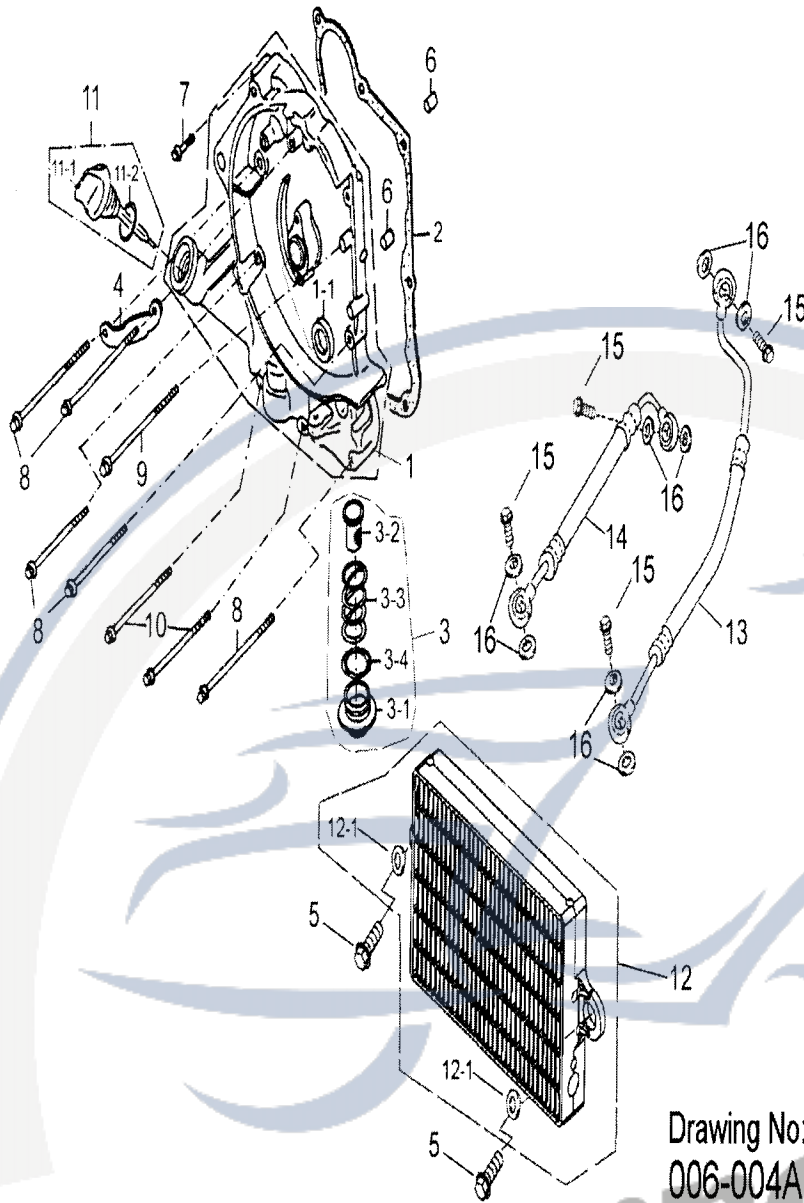

Drawing No:
006-004A

P/N	DESCRIPTION	PART NO.	Q'TY	REMARK
6-1	RIGHT CRANKCASE OVER	11330-156-002	1	
6-1-1	OIL SEAL	96501-19305	1	19.8x30x5
6-2	GASKET R. CRANKCASE COVER	11393-156-000	1	
6-3	CAP TAPPET ADJUSTING HOLE ASS'Y	12361-119-000	1	
6-3-1	CAP TAPPET	12360-119-000	1	
6-3-2	SCREEN OIL FILTER	15421-119-000	1	
6-3-3	SPRING OIL FILTER SPRING	15426-119-000	1	
6-3-4	OIL RING	91330-119-000	1	30.8mm
6-4	CLAMPER A.C.GENERATOR CORD	32961-119-000	1	
6-5	HEX BOLT WITH WASHER	92000-06025-K	2	M6x25
6-6	DOWEL PIN	94301-08140	2	8x14

6-7	HEX FLANGE BOLT	96000-06040-8C	1	M6x40
6-8	HEX FLANGE BOLT	96000-06095-8C	5	M6x95
6-9	HEX FLANGE BOLT	96000-06100-8C	1	M6x100

15.11.2004

6-10	HEX FLANGE BOLT	96000-06110-8C	2	M6x110
6-11	GAUGE ASS'Y OIL LEVEL	1565A-119-000	1	
6-11-1	GAUGE OIL LEVEL	15650-119-000	1	
6-11-2	OIL RING	91318-119-000	1	18x3
6-12	RADIATOR	15215-156-001	1	
6-12-1	RUBBER WASHER	15235-156-000	2	
6-13	LIFE HOSE OUTLET	15230-158-001	1	
6-14	RIGHT HOSE INLET	15220-158-001	1	
6-15	OIL TUBE FIXED BOLT	45456-156-000-G	4	M12x1.25
6-16	PLAIN WASHER	94101-1221320-L	8	12x21.3x2



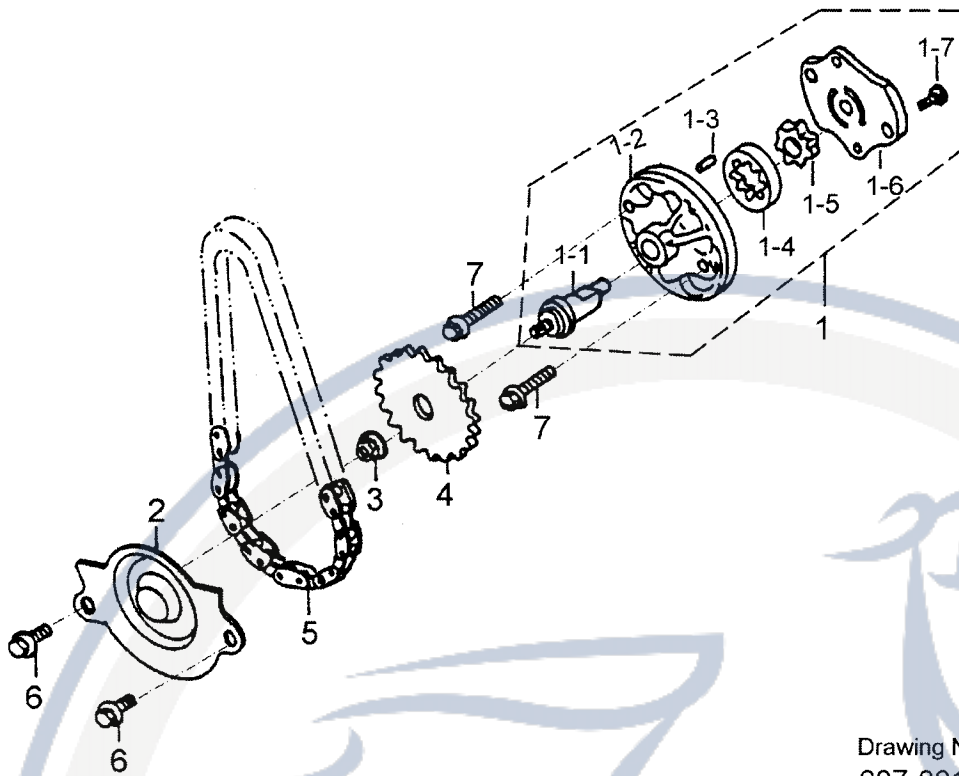

Drawing No:
007-001A

P/N	DESCRIPTION	PART NO.	Q'TY	REMARK
7-1	OIL PUMP	15100-158-000	1	
7-1-1	OIL PUMP PROIMARY AXLE	15131-158-000	1	
7-1-2	BODY OIL PUMP	15132201	1	
7-1-3	DOWEL PIN	94301-04066	1	
7-1-4	ROTOR OIL PUMP OUTER	15133201	1	
7-1-5	ROTOR OIL PUMP INNER	15134201	1	
7-1-6	PLATE OIL PUMP	15135201	1	
7-1-7	PAN PHILLIPS BOLT	93500-03010-B	1	M3x10
7-2	SEPARATOR A OIL	15711-119-000	1	
7-3	HEX FLANGE NUT	94050-06000-C	1	M6
7-4	OIL PUMP DRIVE GEAR	15150-119-000	1	
7-5	CHAIN OIL PUMP	15141-119-000	1	
7-6	HEX FLANGE BOLT	96000-06012-8C	2	M6x12
7-7	PAN SOCKET BOLT	93902-06030-B	2	M6x30

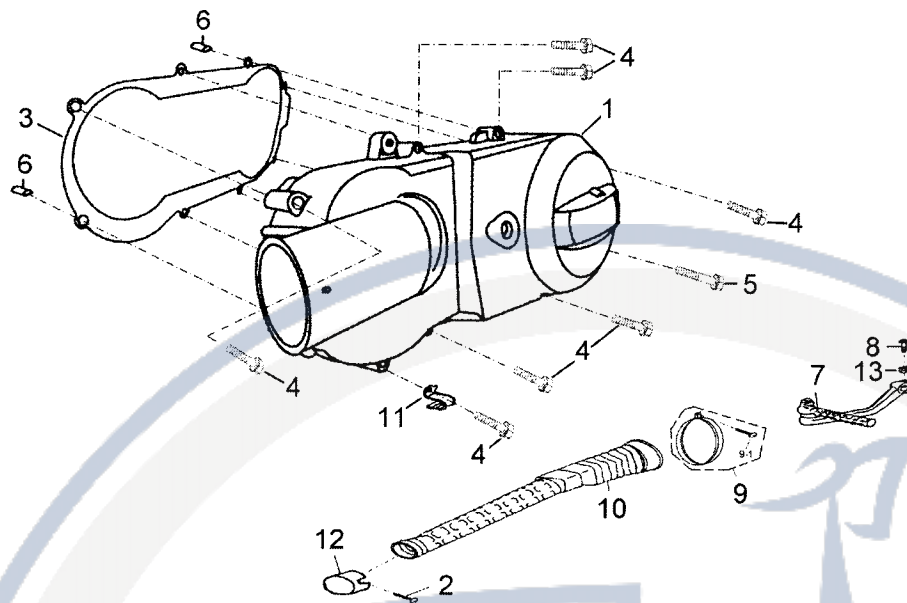

Drawing No:
008-004E

P/N	DESCRIPTION	PART NO.	Q'TY	REMARK
8-1	COVER L	11341-156-001	1	
8-2	TAPPING SCREW	93903-04016-K	1	M4x16
8-3	GASKET L COVER	11359-119-000	1	
8-4	HEX FLANGE BOLT	96000-06040-8C	7	M6x40
8-5	HEX FLANGE BOLT	96000-06100-8C	1	M6x100
8-6	DOWEL PIN	94301-08140	2	8x14
8-7	ARM ASS'Y KICK STARTER	28300-156-000	1	
8-8	HEX FLANGE BOLT	96000-06025-K	1	M6x25
8-9	STRAP	90669-119-001	1	D61
8-9-1	PAN PHILLIPS BOLT	93500-04025-K	1	M4x25
8-10	DUCT L. CRANKCASE COVER	11345-119-000	1	
8-11	BREATHER HOSE CLIP	11351-119-000	1	
8-12	DUST PROOF RUBBER	11349-156-000	1	
8-13	SPRING WASHER	94111-06000-K	1	

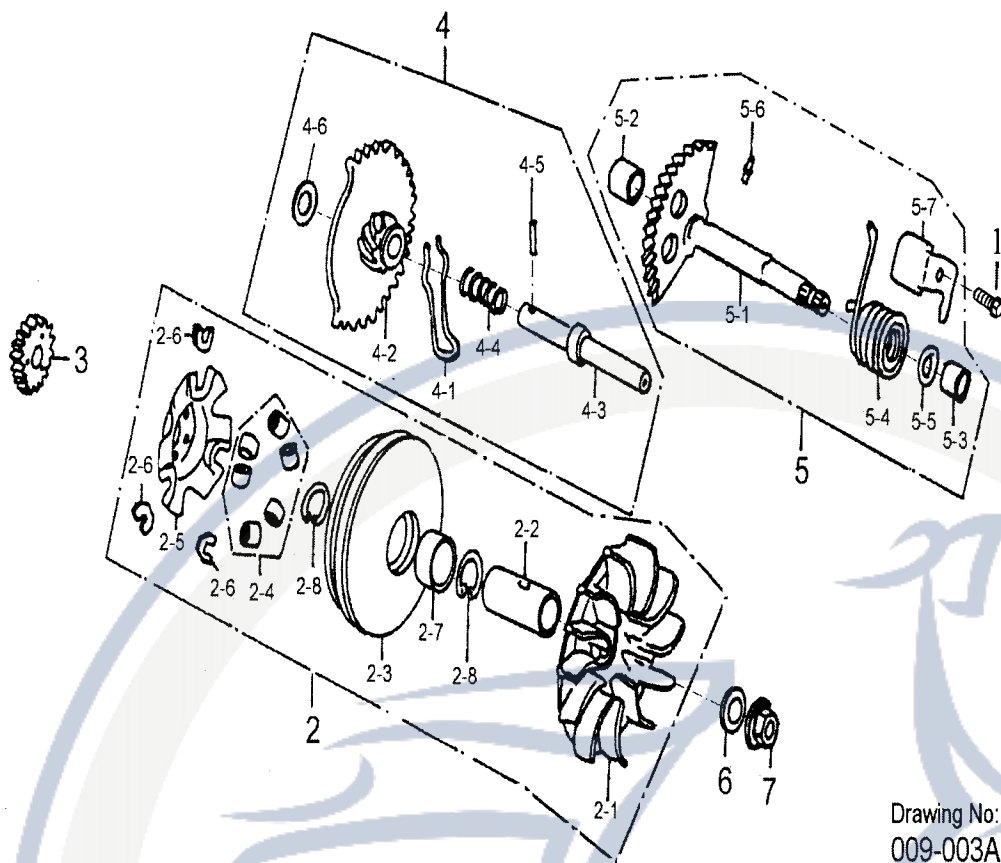

Drawing No:
009-003A

P/N	DESCRIPTION	PART NO.	Q'TY	REMARK
9-1	HEX FLANGE BOLT	96000-06012-8C	1	M6x12
9-2	FACE ASS'Y MOVABLE DRIVE	22103-160-000	1	
9-2-1	FACE DRIVE	22102-156-000	1	
9-2-2	BOSS DRIVE FACE	96401-172451	1	17x24x51.5
9-2-3	PRIMARY SLIDING SLOT WHEEL	22110-156-000	1	
9-2-4	ROLLER COMP WEIGHT	22121-158-000	6	17 g
9-2-5	PLATE RAMP	22131-158-000	1	φ17孔
9-2-6	SIDE PIECE	22132-156-000	3	
9-2-7	BUSH	96401-242830	1	24x28x30
9-2-8	INTERNAL CIR CLIP	94512-2800R	2	RTW-28
9-3	GEAR KICK DRIVE	28211-119-000	1	20T
9-4	STARTER IDLE GEAR ASS'Y	28231-119-000	1	
9-4-1	SPRING STARTER GEAR FRICTION	28223-119-000	1	
9-4-2	GEAR COMP STARTER IDLE	28230-119-000	1	13T/49T
9-4-3	SHAFT STARTER IDLE	28241-119-000	1	
9-4-4	SPRING STARTER IDLE	28242-119-000	1	

9-4-5	SPECIAL PIN	28282-119-000	1	4.5mm
9-4-6	PLAIN WASHER	94101-1225023	1	12x25x2.3
9-5	STARTER SPINDLE ASS'Y	28251-119-000	1	

15.11.2004

9-5-1	STARTER SPINDLE COMP	28250-119-000	1	
9-5-2	BUSH	96401-121612	1	12x16x12
9-5-3	STARTER SPINDLE BUSH	96401-141816	1	14x18x16
9-5-4	STARTER SPRING	28281-119-000	1	
9-5-5	PLAIN WASHER	94101-1422012-K	1	14x22x1.2
9-5-6	ROLLER	96220-30085	1	3x8.5
9-5-7	PLATE KICK RETURN STOPPER	11207-119-000	1	
9-6	PLAIN WASHER	94101-1225023	1	12x25x2.3
9-7	HEX FLANGE NUT	94050-12000-C	1	M12

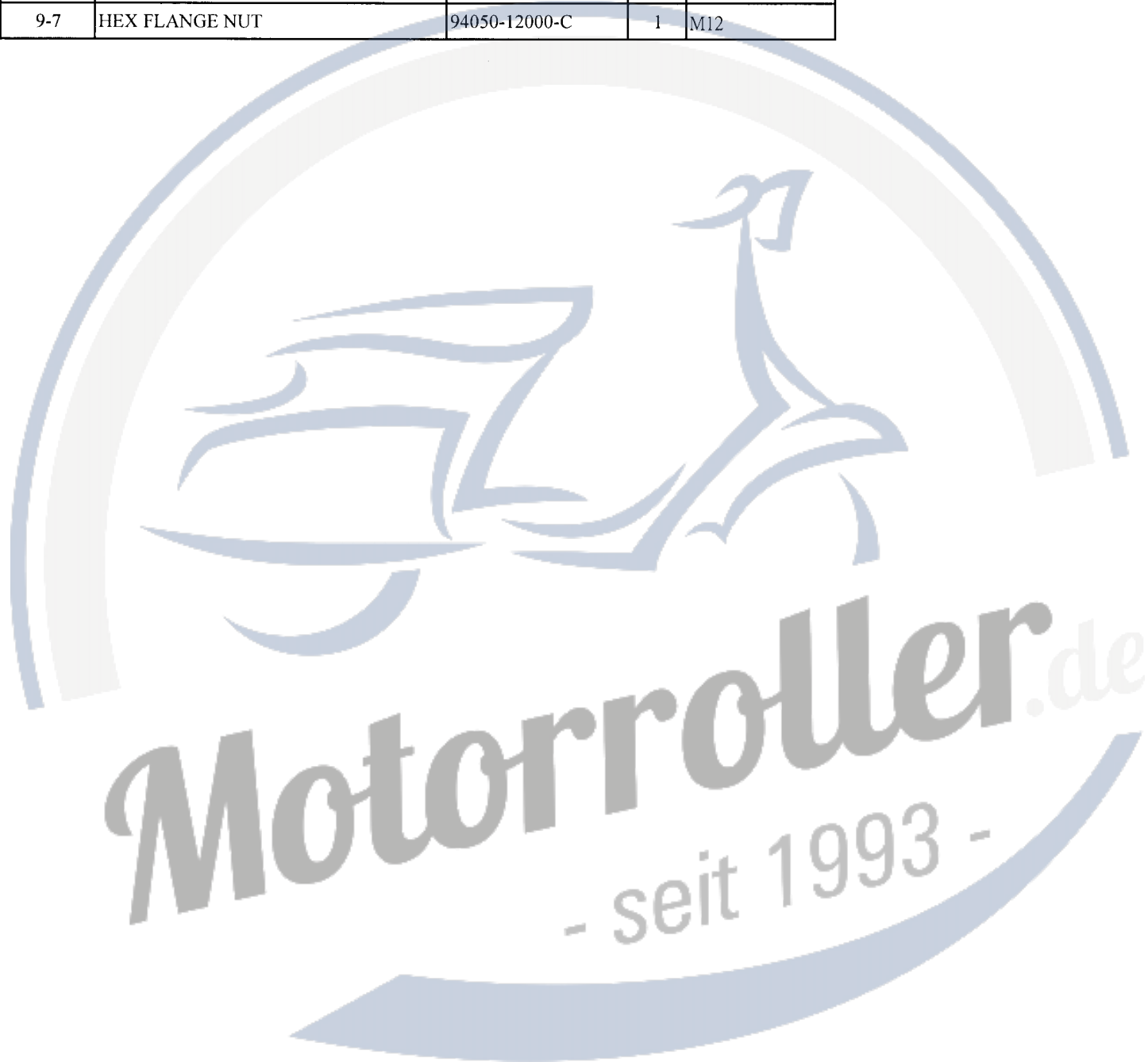

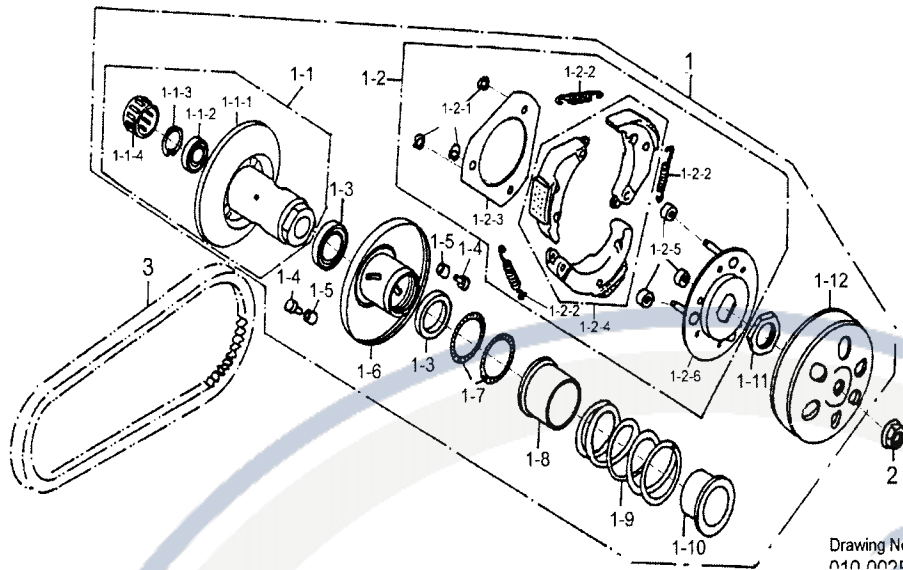

P/N	DESCRIPTION	PART NO.	Q'TY	REMARK
10-1	DRIVE FACE ASS'Y(B)	22000-158-000	1	
10-1-1	SECONDARY FIX SLOT WHEEL	23200-119-000	1	
10-1-1-1	FACE ASS'Y DRIVEN	23210-119-000	1	
10-1-1-2	RADIAL BALL BEARING	96100-6902U	1	6902U
10-1-1-3	INTERNAL CIR CLIP	94512-280IR	1	IRTW-28
10-1-1-4	NEEDLE BEARING	96200-202918	1	20x29x18
10-1-2	PLATE ASS'Y DRIVE	22001-156-000	1	
10-1-2-1	EXTERNAL CIR CLIP	94511-0700E	3	ETW-7
10-1-2-2	SPRING CLUTCH	22401-119-000	3	
10-1-2-3	PLATE CLUTCH SIDE	22351-119-000	1	
10-1-2-4	CLUTCH WEIGHT SET	22535-156-000	3	
10-1-2-5	RUBBER CLUTCH DAMPER	22804-119-000	3	
10-1-2-6	PLATE COMP DRIVE	22350-119-000	1	
10-1-3	OIL SEAL	96500-34414	2	34x41x4
10-1-4	GUIDE PIN	23225-119-000	3	
10-1-5	GUIDE	23226-119-000	3	
10-1-6	SECONDARY SLIDING SLOT WHEEL	23220-119-000	1	
10-1-7	OIL RING	91336-119-000	2	36x2
10-1-8	SECONDARY SPRING SEAT	23237-119-000	1	
10-1-9	COMPRESSION SPRING	23233-158-000	1	
10-1-10	COLLER SPRING	23238-119-000	1	
10-1-11	NUT , SPECIAL	90202-119-000	1	M28
10-1-12	CLUTCH COVER COMP	22100-119-000	1	
10-2	HEX FLANGE NUT	94050-12000-C	1	M12
10-3	BELT DRIVE	23100-122-000	1	743x20x30

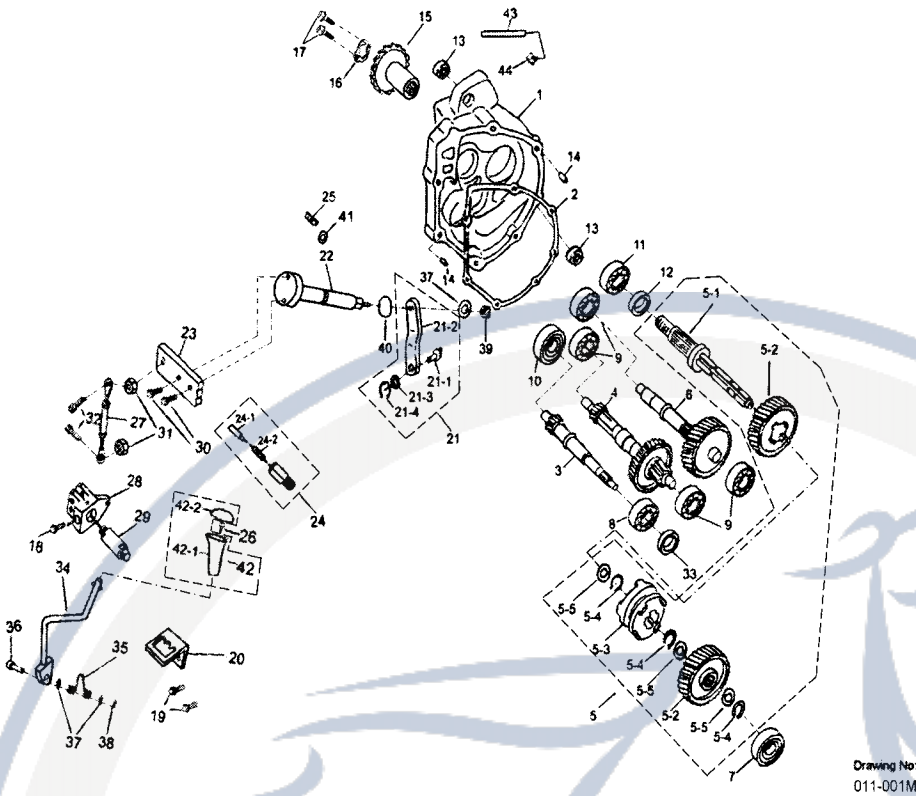

P/N	DESCRIPTION	PART NO.	Q'TY	REMARK
11-1	MISSION COVER	21301-158-002	1	
11-2	MISSION COVER GASKET	21395-156-000	1	
11-3	SHAFT , DRIVE	23411-119-000	1	
11-4	MAIN AXLE COMP	23420-156-000	1	
11-5	SHAFT , FINAL ASS'Y	23440-156-002	1	
11-5-1	SHAFT , FINAL	23431-156-002	1	
11-5-2	GEAR , TRANSMISSION	23434201-000	2	
11-5-3	CLUTCH	28430201-000	1	
11-5-4	C - CIRCLIP	23436201-000	3	
11-5-5	SPECIAL WASHER	23435201-000	3	
11-6	COUNTER SHAFT ASS'Y	23433-156-000	1	
11-7	BEARING	96100-62030	1	CS05 6203
11-8	BEARING	96100-6204JR2C3	1	JR2C3 6204
11-9	BEARING	96100-62020	4	CS05 6202
11-10	BEARING	96100-TMB301	1	TMB301
11-11	BEARING	96100-6004U	1	6004U
11-12	OIL SEAL	96500-30477	1	
11-13	RUBBER BUSH	96400-082223	2	8x22x23
11-14	DOWEL PIN	94301-08140	2	8x14

11-15	DRIVE SPROCKET	23801-159-001	1	
11-16	SPROKET BRACKET	23811201-000	1	
11-17	HEX BOLT	92000-06010-C	2	

11-18	HEX FLANGE BOLT	96000-06025-K	1	M6x25
11-19	HEX FLANGE BOLT	96000-06012-10K	2	M6x12
11-20	FIX CATCH SUPPORT	21323-156-002	1	
11-21	TRANSMISSION FORK ASS,Y	21310-156-000	1	
11-21-1	TRANSMISSION FORK	21311-156-000	1	
11-21-2	TRANSMISSION SHAFT	21312-156-000	1	
11-21-3	SPECLAL WASHER	23437-156-000	1	
11-21-4	C - CINCLIP	23438-156-000	1	
11-22	TRANSMISSION LINK	21313-156-000	1	
11-23	TRANSMISSION POSITION FIX PLATE	21314-156-001	1	
11-24	TRANSMISSION POSITION FIX BUTTON	21315-156-000	1	
11-24-1	TRANSMISSION FIX PIN	21324-156-000	1	
11-24-2	TRANSMISSION FIX SPRING	21325-156-000	1	
11-25	HEX SOCKET FIX BOLT	91000-05009-K	1	M5x9
11-26	HEX FLANGE BOLT	96000-06016-K	1	M6x16
11-27	TRANSMISSION FORK LINK	21316201-000	1	
11-28	TRANSMISSION SET	21317-156-001	1	
11-29	TRANSMISSION SET FIX LINK ASS,Y	21318-156-001	1	
11-30	HEX FLANGE BOLT	96000-06012-10C	2	耐落 M6x12
11-31	NYLON INSERT LOCK NUT	90350-06000-K	2	M6
11-32	HEX SOCKET BOLT	91000-06025-K	2	M6x25
11-33	OIL SEAL	96500-20326	1	20x32x6
11-34	TRANSMISSION LEVER	21319201-000	1	
11-35	TRANSMISSION LEVER SPRING	21320201-000	1	
11-36	TRANSMISSION LEVER FIX PIN	21321-156-000	1	
11-37	PLAIN WASHER	94101-0816015-C	3	8x16x1.5
11-38	COTTER PIN	94201-24190	1	
11-39	HEX NUT WITH SERRATION	90350-08000-UK	1	
11-40	O-RING	91312-111-000	1	
11-41	PLAIN WASHER	94101-0510010-B	1	5x10x1
11-42	TRANSMISSION LEVER ROD ASS'Y	21326-158-000	1	
11-42-1	TRANSMISSION LEVER ROD	21328-158-000	1	
11-42-2	TRANSMISSION LEVER COVER	21327-158-000	1	
11-43	TUBE BREATHER	94408-05007-170	1	5x7(L=170mm)
11-44	BREATHER JOINT	16610-113-000	1	

D-12 CRANKCASE

15.11.2004

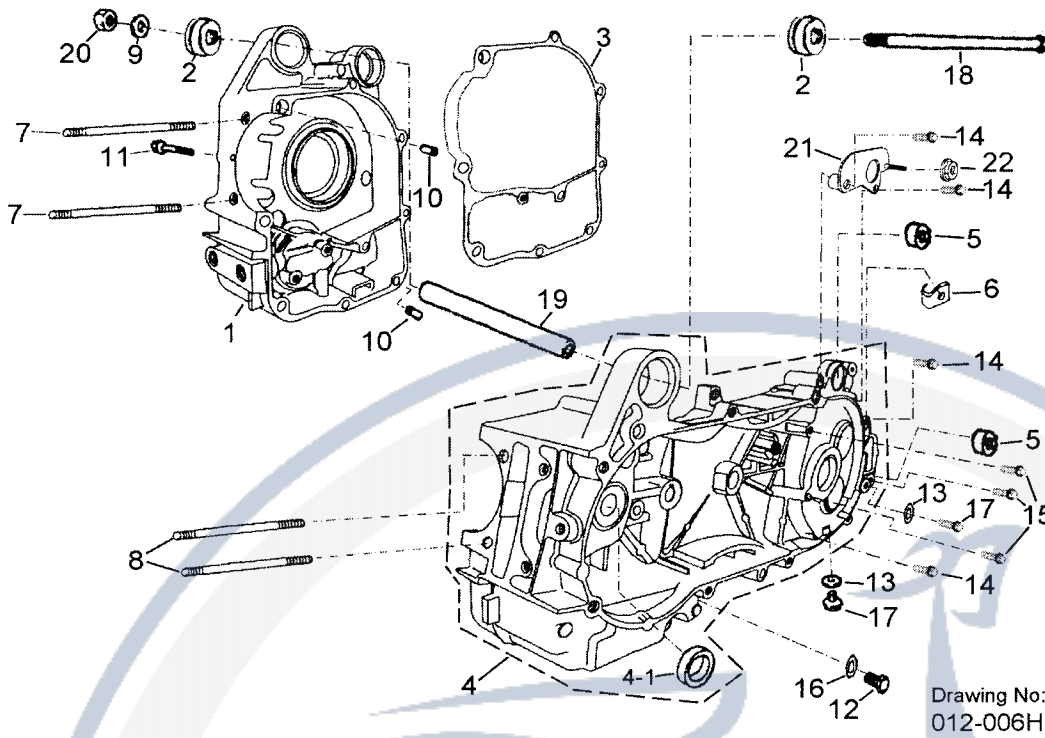

P/N	DESCRIPTION	PART NO.	Q'TY	REMARK
12-1	RIGHT CRANKCASE	11101-158-000	1	
12-2	BUSH ENGINE HANGER RUBBER	96400-102822	2	10x28x22
12-3	GASKET CRANKCASE	11191-122-000	1	
12-4	LEFT CRANKCASE	11201-158-004	1	
12-4-1	OIL SEAL	96501-19305	1	19.8x30x5
12-5	RUBBER BUSHING	96400-082223	2	8x22x23
12-6	CARBUBETOR TUBE BRACKET	11351-111-000	1	
12-7	STUD BOLT	91001-08181-C	2	M8x181
12-8	STUD BOLT	91001-08187-C	2	M8x187
12-9	PLAIN WASHER	94101-1022020-C	1	10x22x2
12-10	DOWEL PIN	94301-08140	2	8x14
12-11	HEX FLANGE BOLT	96000-06050-C	1	M6x50
12-12	HEX FLANGE BOLT	96000-12015-14C	1	M12x15
12-13	PLAIN WASHER (ALUMINUM)	94101-0816020-L	2	8x16x2

12-14	HEX FLANGE BOLT	96000-06060-8C	4	M6x60
12-15	HEX FLANGE BOLT	96000-06070-8C	3	M6x70
12-16	PLAIN WASHER	94101-1221320-L	1	12x21.3x2
12-17	HEX FLANGE BOLT	96000-08012-10C	2	M8x12
12-18	HEX FLANGE BOLT	96000-10197-14C	1	M10x197
12-19	ENGING SPACER COLLAR	11150-156-001	1	10x17x124.5
12-20	NYLON INSERT LOCK NUT	90350-10000-C	1	M10
12-21	AIR CLEANER FIX PLATE	17237201-000	1	
12-22	HEX FLANGE NUT	94050-06000-K	1	

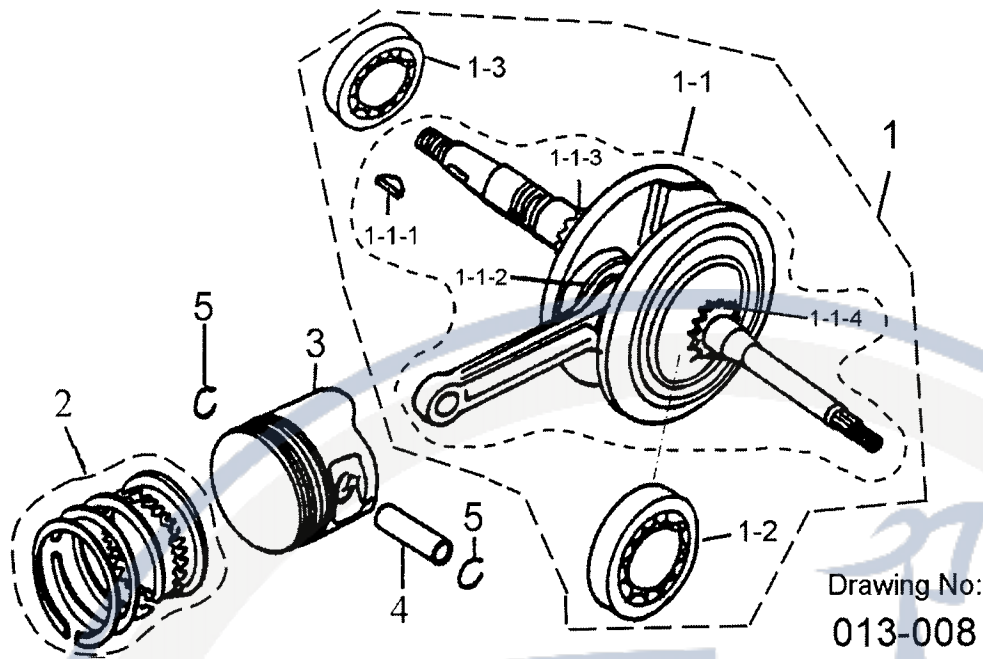

P/N	DESCRIPTION	PART NO.	Q'TY	REMARK
13-1	CRANKSHAFT ASS'Y	13000202-000	1	
13-1-1	CRANKSHAFT KIT	13005202	1	
13-1-1-1	SEMICYCLE KEY	90471-119-000	1	25x4x14
13-1-1-2	NEDDLE BEARING	96200-283313	1	
13-1-1-3	CAM TRANSMISSION GEAR	14322-119-000	1	
13-1-1-4	TIMING GEAR	14311-119-000	1	17T
13-1-2	BEARING	TMB305V32	1	
13-1-3	BEARING	CSSC04A86CS12	1	
13-2	PISTON RING SET	13011-158-000	1	
13-3	PISTON	13100-158-000	1	
13-4	PISTON PIN	13111-158-000	1	10x15x42
13-5	CLIP PISTON PIN	13115-119-001	2	

14-1-23	CLIP	94510-08000	1	8x0.8
14-1-24	BREATHER TUBE ASS'Y	11210-119-000	1	
14-1-25	CLAMP TUBE	94509-08500	1	
14-2	HEX FLANGE BOLT	96000-06032-816C	1	M6x32
14-3	ANTI-VIBRATION RUBBER	81113-153-000	1	

15.11.2004



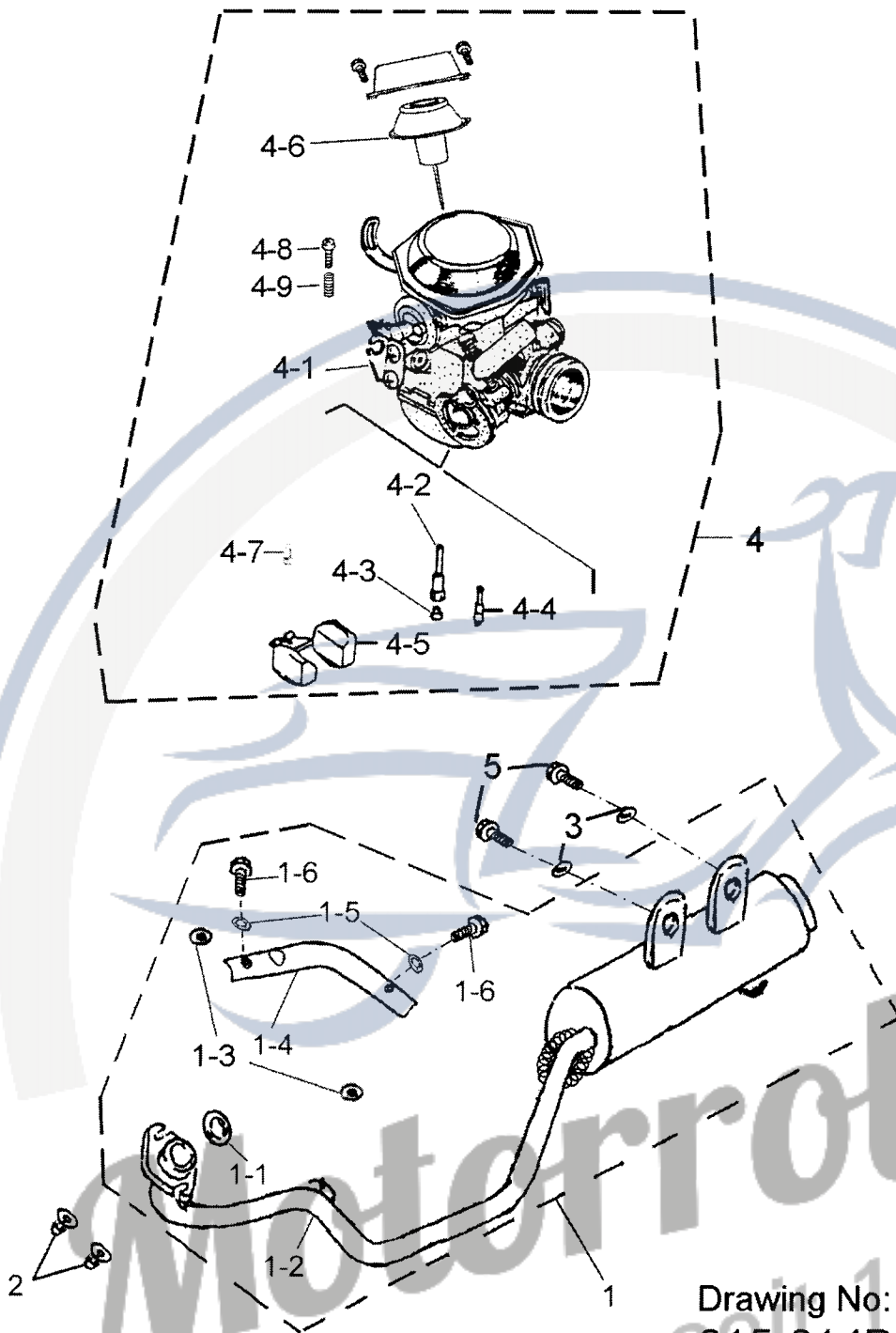

Drawing No:
015-014P

P/N	DESCRIPTION	PART NO.	Q'TY	REMARK
15-1	EXHAUST PIPE ASS'Y	18300-186-001	1	打刻AT-36
15-1-1	EXHAUST PIPE GASKET	18291-119-000	1	25.4x33x4
15-1-2	EXHAUST PIPE	18301-186-001	1	
15-1-3	GASKET	94102-08517020	2	8.5x17x2
15-1-4	EXHAUST PIPE PROTECTOR	18315-156-001	1	
15-1-5	GASKET	94102-0613010	2	6x13x1
15-1-6	HEX FLANGE BOLT	96000-06010-B	2	M6x10
15-2	NUT CAP	90301-08000-C	2	M8
15-3	PLAIN WASHER	94101-0822020-C	2	8x22x2

15.11.2004

15-4	CARBURETOR ASS'Y	16100203-000	1	TM35180
15-4-1	THROTTLE CABLE FIX SEAT	16120-119-000	1	
15-4-2	NEEDLE NOZZLE	16105-182-000	1	
15-4-3	MAIN NOZZLE	16108202-000	1	120
15-4-4	PILOT JET	16110-182-000	1	22,5
15-4-5	FLOAT	16118-182-000	1	
15-4-6	PISTON THROTTLE VALVE ASS'Y	16050202-000	1	
15-4-7	NEEDLE VAVLE SET	16117201-000	1	
15-4-8	IDLE ADJUST BOLT	16171201	1	
15-4-9	SPRING	16172201	1	
15-5	HEX FLANGE BOLT	96000-08016-KL	2	M8x16

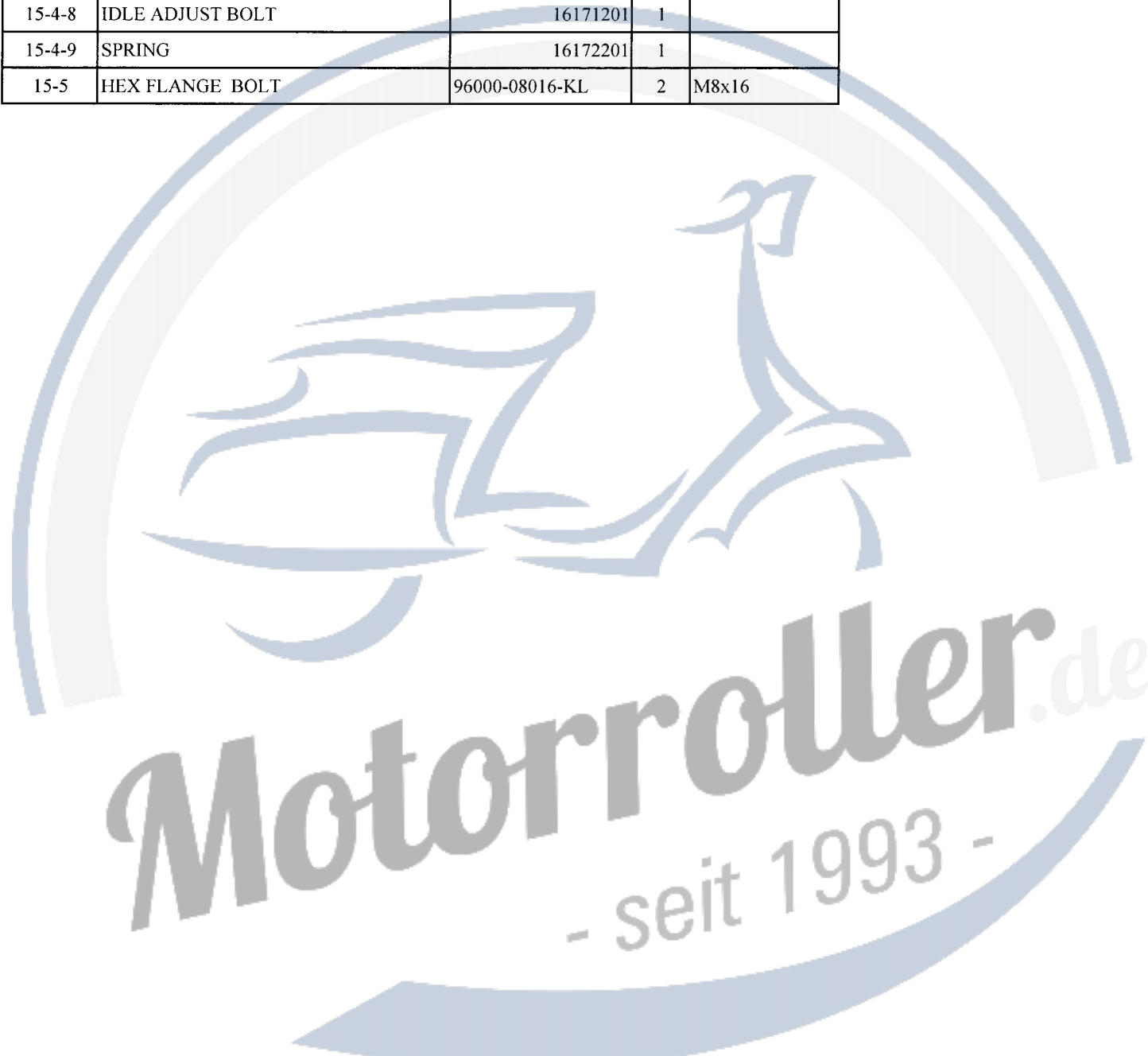

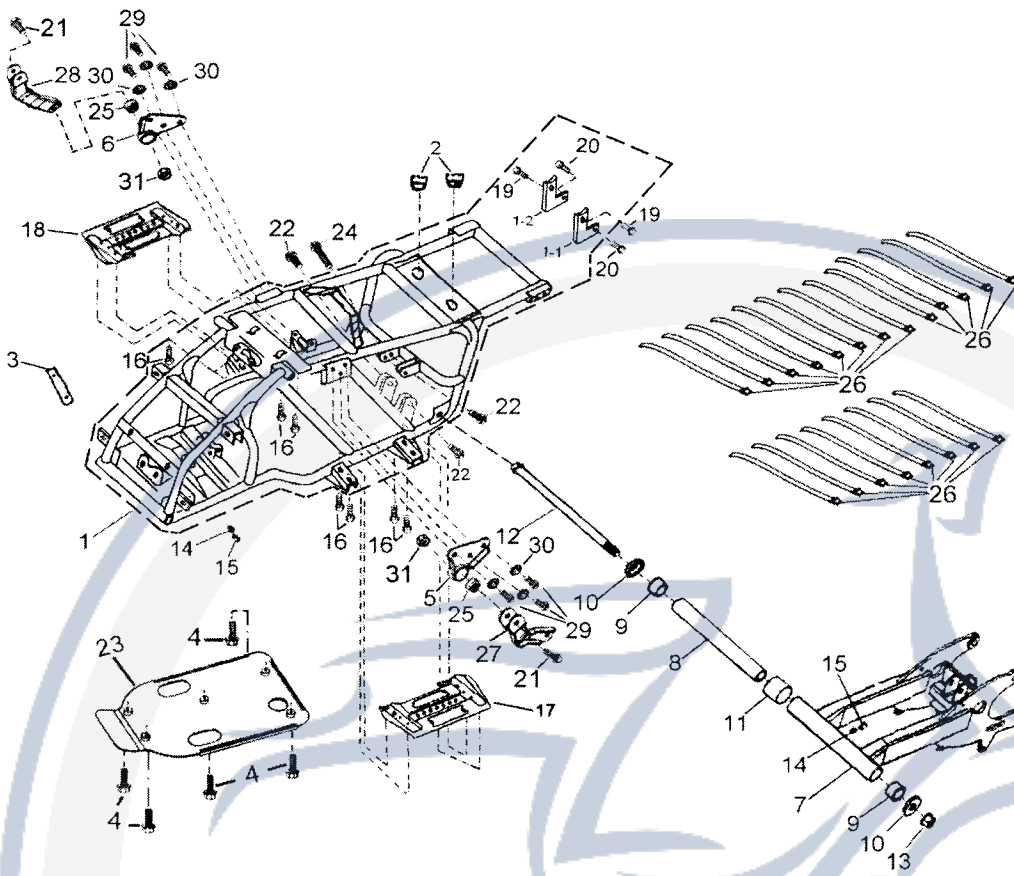

Drawing No:
016-078

P/N	DESCRIPTION	PART NO.	Q'TY	REMARK
16-1	FRAME COMP	50100-182-A01	1	
16-1-1	LICENSE PLATE BRACKET(L)	33706201-000	1	
16-1-2	LICENSE PLATE BRACKET(R)	33717201-000	1	
16-2	SEAT RUBBER	77220-131-000	2	φ37xφ13x23
16-3	FLANGE NUMBER PLATE	50130-131-000	1	
16-4	HEX BOLT WITH WASHER	92000-06016-K	5	M6x16
16-5	CONNECTER PLATE(LEFT)	50371201-000	1	
16-6	CONNECTER PLATE(RIGHT)	50372201-000	1	
16-7	SWING ARM SUB ASS'Y	52410-182-A03	1	
16-8	SWING ARM SPACER TUBE	52420-131-000	1	

16-9	GREASE CONTAIN SEAT	52421-131-000	2	
16-10	SWING ARM SEAT COVER	52422-131-000	2	
16-11	RUBBER SLEEVE	52423-156-000	1	
16-12	HEX FLANGE BOLT	96000-14290-C	1	M14x290
16-13	INSERT LOCK NUT	90350-14000-UC	1	M14
16-14	GREASE VALVE	51300-131-000	2	

16-15	GREASE VALVE RUBBER CAP	51301-131-000	2	
16-16	HEX FLANGE BOLT	96000-08012-K	8	M8x12
16-17	RIGHT FOOTWELL BOTTOM BOARD	51105-156-000	1	
16-18	LEFT FOOTWELL BOTTOM BOARD	51120-156-000	1	
16-19	HEX BOLT WITH SPRING WASHER	92001-08016-K	2	M8x16
16-20	HEX BOLT WITH WASHER	92300-06016-K	2	M6x16
16-21	HEX FLANGE BOLT	96000-10043-KL	2	M10x43
16-22	HEX FLANGE BOLT	96000-08040-K	3	M8x40
16-23	PROTECTION FRAME BOTTOM BOARD	50106-158-000	1	
16-24	HEX FLANGE BOLT	96000-08125-K	1	M8x125
16-25	RUBBER BUSHING	96400-102822	2	
16-26	STRAP	90569-131-000	21	
16-27	LEFT ENGINING BRACKET PLATE	50355202-000	1	
16-28	RIGHT ENGINING BRACKET PLATE	50351202-000	1	
16-29	HEX FLANGE BOLT	96000-10020-KL	6	M10x20
16-30	SPRING WASHER	94111-10000-K	6	M10
16-31	NYLON INSERT LOCK NUT	90350-10000-UC	2	M10

Motorroller.de
- seit 1993 -

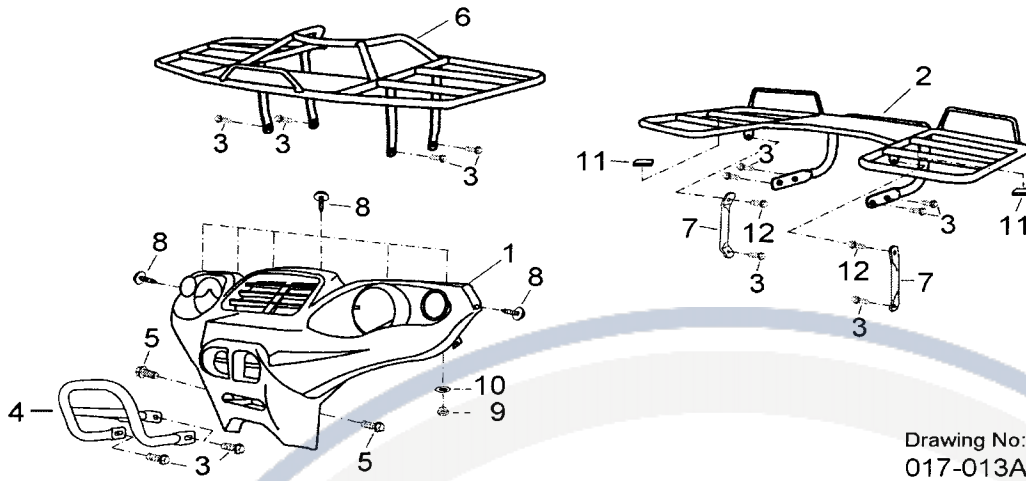

Drawing No:
017-013A

P/N	DESCRIPTION	PART NO.	Q'TY	REMARK
17-1	BUMPER COVER	50460-182-000	1	
17-2	REAR IRON RACK	81111-182-A00	1	
17-3	HEX BOLT WITH SPRING WASHER	92001-08016-K	14	M8x16
17-4	BUMPER	50455-182-A00	1	
17-5	HEX BOLT WITH FIX WASHER	92003-06016-K	2	M6x16
17-6	FRONT IRON RACK	50495-182-A00	1	
17-7	REAR RACK BRACKET	81121-182-A00	2	
17-8	PAN PHILLIPS BOLT	93100-05016-K	8	M5x16
17-9	NYLON INSERT LOCK NUT	90350-05000-K	8	M5
17-10	PLAIN WASHER	94101-0514010-K	8	ψ5xψ14x1mm
17-11	ANTI-VIBRATION RUBBER	81113-153-000	2	
17-12	HEX BOLT WITH SPRING WASHER	92001-08020-K	2	M8x20

Motorroller.de
- seit 1993 -

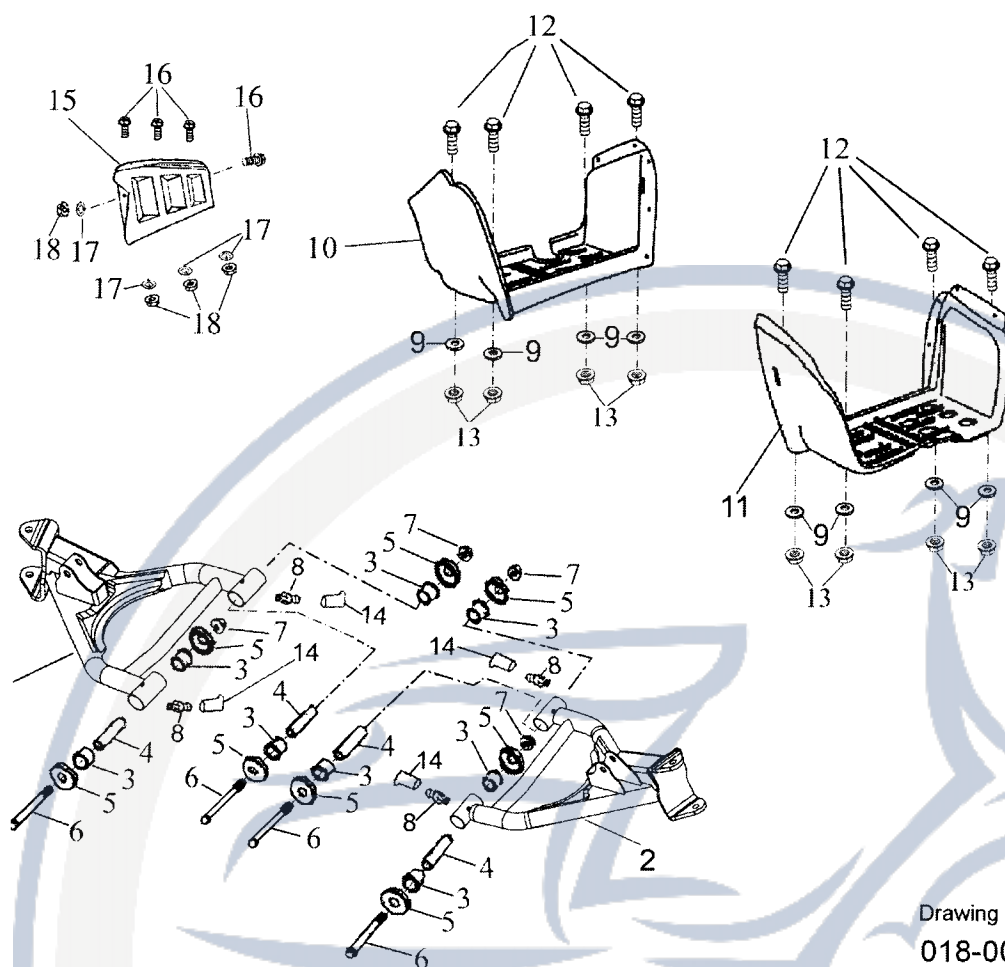

Drawing N
018-001

P/N	DESCRIPTION	PART NO.	Q'TY	REMARK
18-1	RIGHT SUSPENSION ARM	53030202-A	1	
18-2	SUSPENSION ARM	53130202-A	1	
18-3	SUSPENSION ARM BUSH	53135-156-000	8	15.5x21x18
18-4	SPACER TUBE	53140-156-000	4	10x15x55
18-5	DUST PROOF RUBBER	52426-156-000	8	
18-6	HEX FLANGE BOLT	96000-10075-KL	4	M10x75
18-7	HEX FLANGE NUT	94050-10000-C	4	M10
18-8	GREASE VALVE	51300-131-000	4	
18-9	PLAIN WASHER	94101-0613010-K	8	6x13x1
18-10	RIGHT FOOTREST	64300-156-002	1	
18-11	LEFT FOOTREST	64310-156-001	1	
18-12	HEX BOLT WITH WASHER	92000-06016-K	8	M6x16
18-13	NYLON INSERT LOCK NUT	90350-06000-K	8	M6

18-14	GREASE VALVE RUBBER CAP	51301-131-000	4	
18-15	HEAT SHIELD	50480-156-000	1	
18-16	PAN PHILLIPS BOLT	93100-05016-K	4	M5x16

18-17	PLAIN WASHER	94101-0514010-K	4	5x14x1
18-18	NYLON INSERT LOCK NUT	90350-05000-K	4	M5

15.11.2004



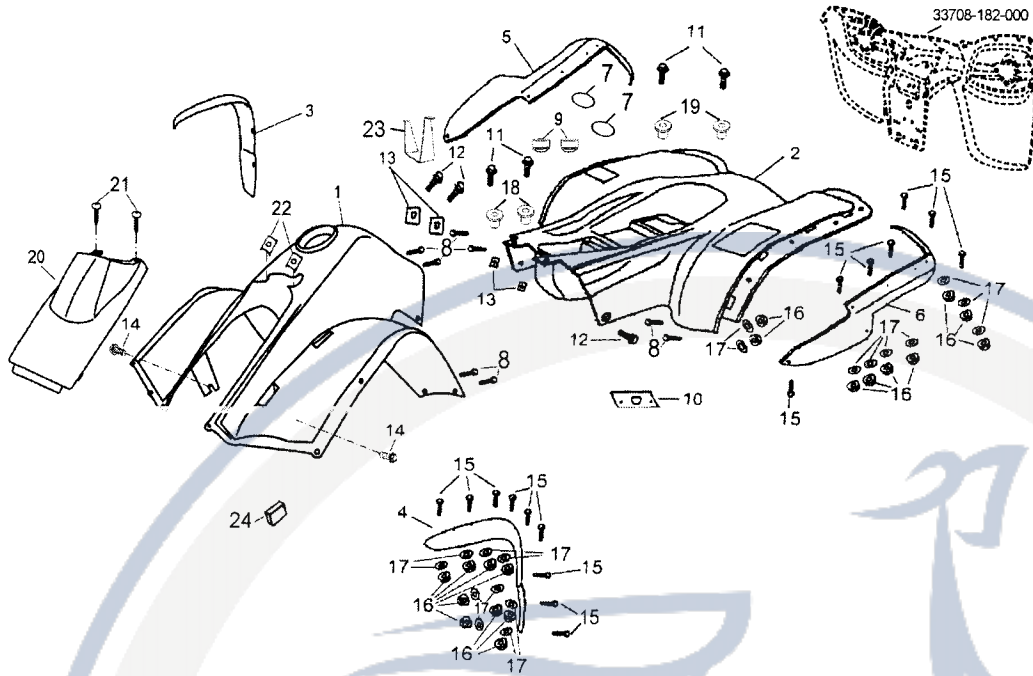

Drawing No:
019-016G

P/N	DESCRIPTION	PART NO.	Q'TY	REMARK
19-1	FRONT FENDER	61100-182-485	1	
19-1	FRONT FENDER	61100-182-G617	1	
19-2	REAR FENDER	61000-182-R485	1	
19-2	REAR FENDER	61000-182-G617	1	
19-3	FRONT RH. MUDFLAP	61105-182-000	1	
19-4	FRONT LH. MUDFLAP	61110-182-000	1	
19-5	REAR RH. MUDFLAP	61005-182-000	1	
19-6	REAR LH. MUDFLAP	61010-182-000	1	
19-7	O-RING	91315-131-000	2	ψ45.7xψ3.5
19-8	PAN PHILLIPS BOLT	93100-05012-K	8	M5x12
19-9	BATTERY RUBBER	31510201-01	2	
19-10	PROTECTOR PAD	80140-131-000	1	
19-11	HEX BOLT WITH PLAIN WASHER	92000-06016-K	4	M6x16
19-12	PAN PHILLIPS BOLT WITH PLAIN WASHER	96318-06016-K	4	M6x16
19-13	U PLATE NUT	90344-06000-C	4	M6

19-14	HEX BOLT WITH FIX WASHER	92003-06016-K	2	
19-15	PAN PHILLIPS BOLT	93100-05016-K	32	M5x16
19-16	NYLON INSERT LOCK NUT	90350-05000-K	40	M5

19-17	PLAIN WASHER	94101-0514010-K	40	ψ5xψ14x1mm
19-18	FLANGE WASHER	94150-0717050-K	2	6.5x17.5x3
19-19	FLANGE WASHER	94150-0717075-K	2	6.5x17.5x5.5
19-20	FRONT FENDER COVER	61300-182-R485	1	
19-20	FRONT FENDER COVER	61300-182-G617	1	
19-21	TAPPING SCREW	93903-04012-K	2	M4x12
19-22	U PLATE NUT	90345-04000-2T	2	
19-23	BATTERY BRACKET	31521201	1	
19-24	ANTI-VIBRATION RUBBER	81113-153-000	1	

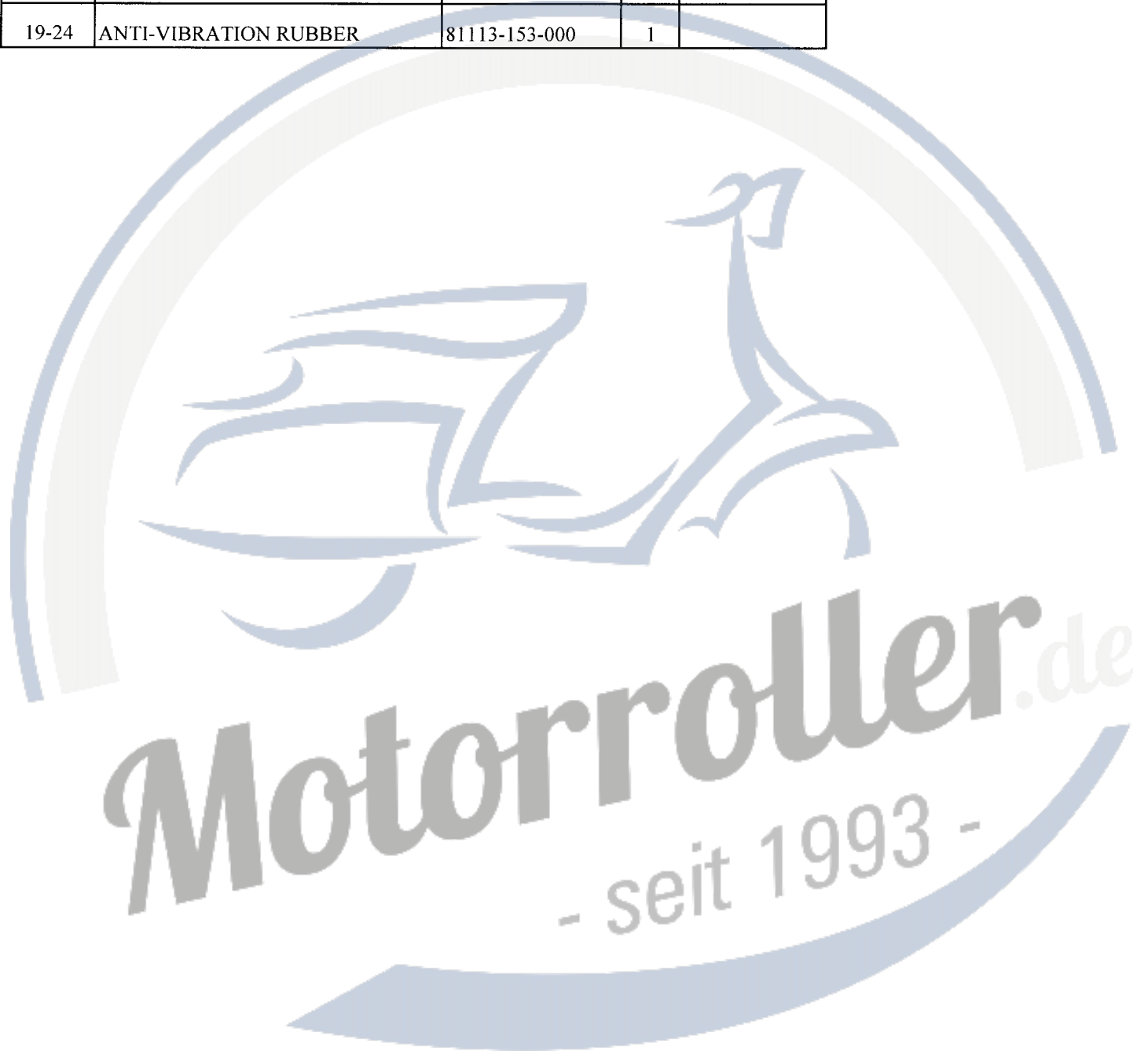

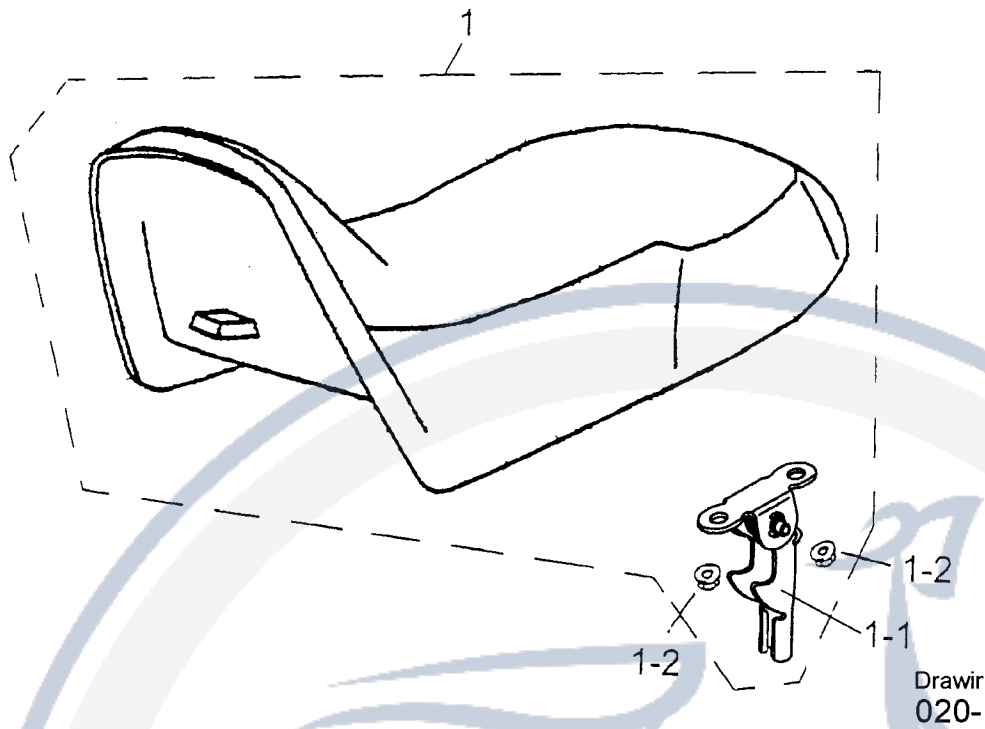

P/N	DESCRIPTION	PART NO.	Q'TY	REMARK
20-1	SEAT ASS'Y	77200-182-000	1	
20-1-1	SEAT FIX HOOK	77210-131-000	1	
20-1-2	HEX FLANGE NUT	94050-06000-C	2	M6

Motorroller.de
- seit 1993 -

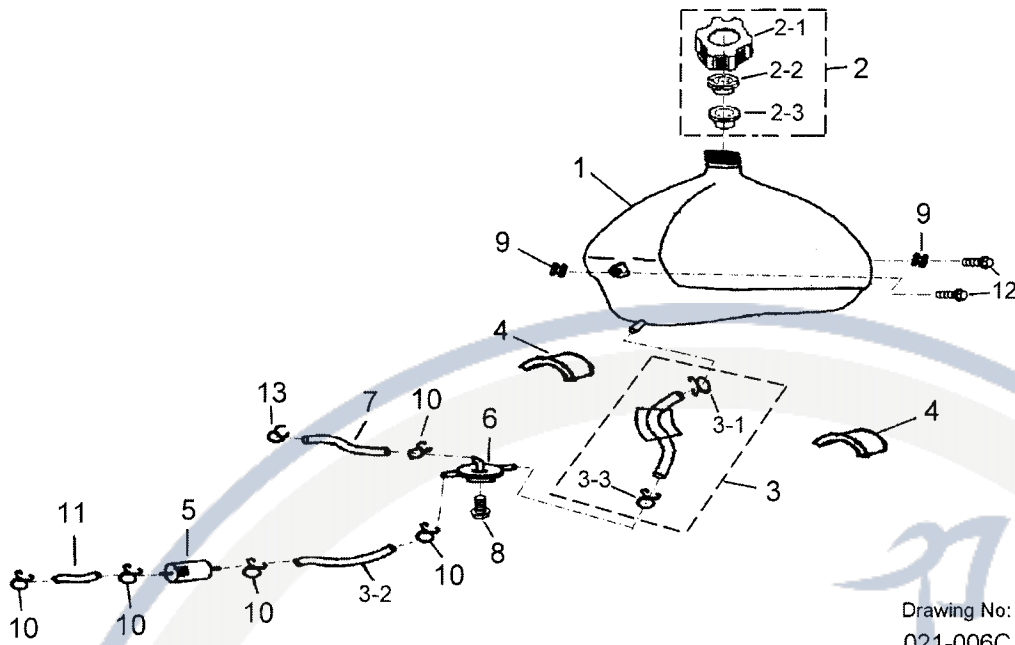

Drawing No:
021-006C

P/N	DESCRIPTION	PART NO.	Q'TY	REMARK
21-1	FUEL TANK COMP	17500-156-000	1	
21-2	FUEL TANK CAP ASS'Y	17620-156-000	1	
21-2-1	FUEL TANK CAP	17623-156-000	1	
21-2-2	BREATHER SHEET	17621-156-000	1	
21-2-3	BREATHER FILM	17625-131-001	1	
21-3	FUEL TUBE A	94401-05009-1	1	210mmxØ5擴孔 Ø6.5
21-3-1	CLIP	94510-12000	1	
21-3-2	FUEL TUBE B	94400-05009-50	1	5x9(L=50)
21-3-3	CLIP	94510-08000	1	8x0.8
21-4	FUEL TANK RUBBER MAT	64319-131-000	2	
21-5	FUEL FILTER ASSY	16952-111-000	1	
21-6	COCK ASS'Y,FUEL AUTO	16950-111-000	1	
21-7	AIR TUBE	94400-04008-300	1	4x8(L=300) ; W= 16.8g
21-8	HEX FLANGE BOLT	96000-06016-K	1	M6x16
21-9	GROMMER	83574-131-000	2	
21-10	CLIP	94510-08000	5	8x0.8
21-11	FUEL TUBE C	94401-05009-50	1	
21-12	HEX BOLT WITH FIX WASHER	92000-06016-K	2	M6x16
21-13	CLIP	94510-06000	1	6x0.8

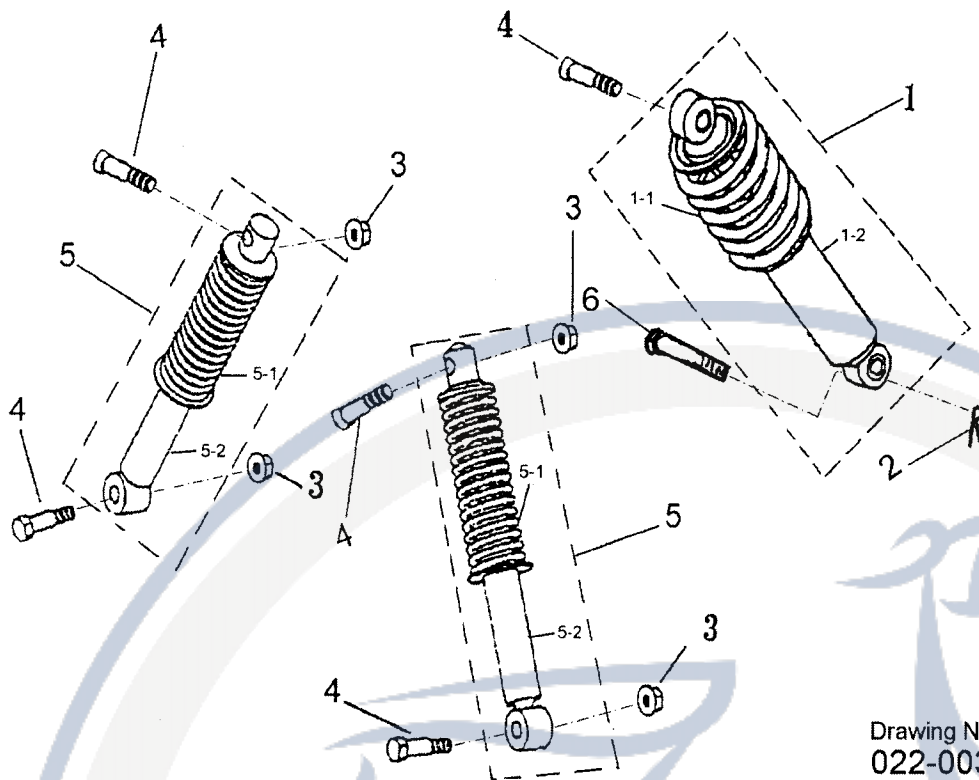

Drawing No:
022-003

P/N	DESCRIPTION	PART NO.	Q"TY	REMARK
22-1	REAR SUSPENSION	52400205-000	1	
22-1-1	REAR SUSPENSION SPRING	52401-156-00B	1	
22-1-2	REAR SUSPENSION INNER TUBE COMP	52402-156-000	1	
22-2	COTTER PIN	94201-24190	1	
22-3	HEX FLANGE NUT	94050-10000-C	4	M10
22-4	HEX FLANGE NUT	96000-10040-KL	5	M10x40(黒)
22-5	FRONT SUSPENSION	51100-156-00B	2	K=3.8/4.5、
22-5-1	FRONT SUSPENSION SPRING	51101-156-00B	2	紅色
22-5-2	FRONT SUSPENSION INNER TUBE COMP	51102-156-000	2	
22-6	REAR SUSPENSION FIX AXLE	52415-156-000	1	Ø12x70

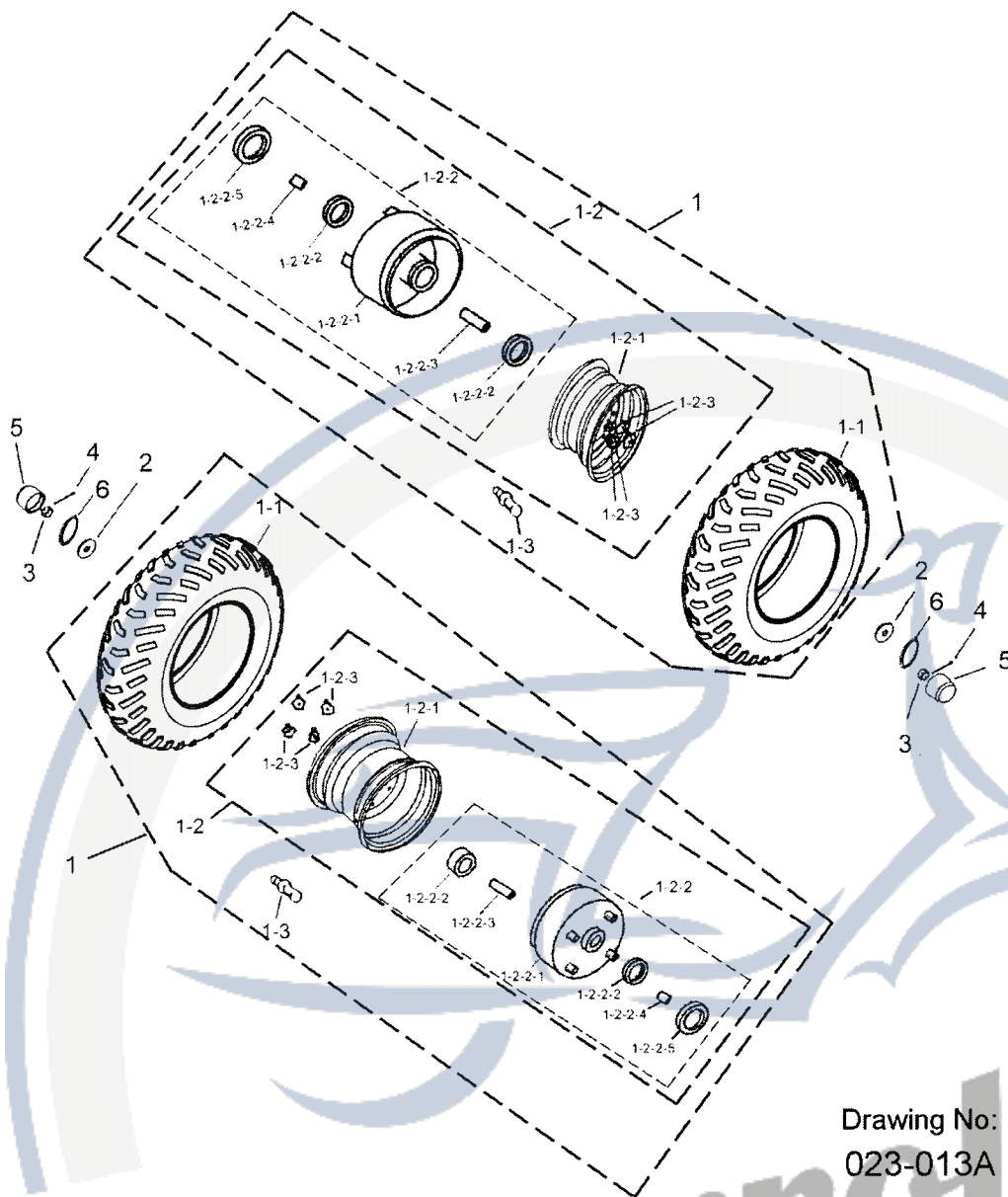

Drawing No:
023-013A

P/N	DESCRIPTION	PART NO.	Q'TY	REMARK
23-1	FRONT WHEEL ASS'Y	42700-182-001	2	21x7-10
23-1-1	TIRE	42711-182-000	2	21x7-10 M901
23-1-2	FRONT RIM ASS'Y	42705-182-001	2	
23-1-2-1	WHEEL	42701-182-000	2	10"x5.5
23-1-2-2	FRONT BRAKE DRUM ASS'Y	45005-156-002	2	

23-1-2-2-1	FRONT BRAKE DRUM	45008-156-002	2	
23-1-2-2-2	BEARING	96100-6003ZZ	4	6003ZZ
23-1-2-2-3	INSIDE SPACER COLLAR	44311-156-001	2	
23-1-2-2-4	OUTSIDE SPACER COLLAR	44312-156-001	2	
23-1-2-2-5	OIL SEAL	96500-2335060	2	23x35x6
23-1-2-3	NYLON INSERT LOCK NUT	90350-10000-UC	8	M10
23-1-3	RIM VALVE	42616-131-000	2	
23-2	PLAIN WASHER	94101-1443030-C	2	φ14.1xφ43x3
23-3	INSERT LOCK NUT	90353-14000-C	2	M14

23-4	COTTER PIN	94201-32320	2	3.2x32
23-5	RUBBER CAP	42730-151-000	2	
23-6	WASHER	15152202	2	14x26x1.6

15.11.2004



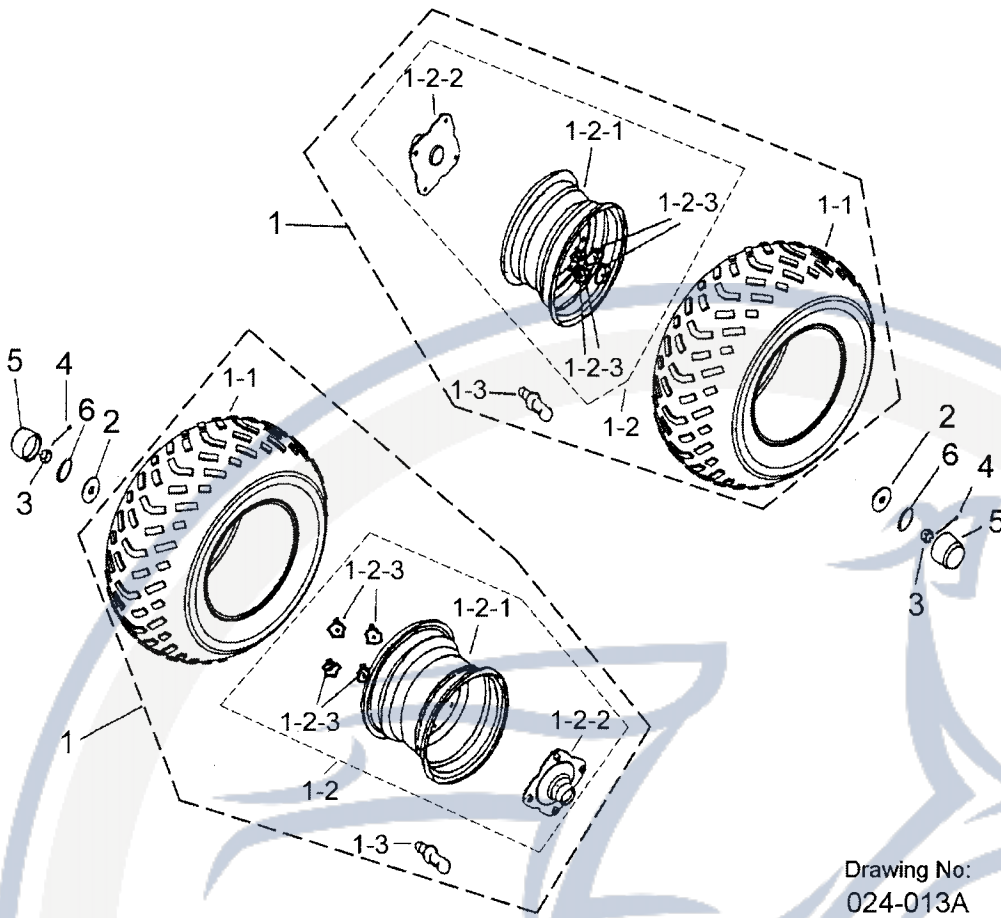

Drawing No:
024-013A

P/N	DESCRIPTION	PART NO.	Q'TY	REMARK
24-1	REAR WHEEL ASS'Y	42800214	2	22x10-8
24-1-1	TIRE	42811-182-000	2	22x10-8 M902
24-1-2	REAR RIM ASS'Y (R)	42706-182-000	2	
24-1-2-1	WHEEL	42801-182-000	2	8"x8"
24-1-2-2	SHAFT CONNECTER	97010202	2	
24-1-2-3	NYLON INSERT LOCK NUT	90350-10000-UC	8	M10
24-1-3	RIM VALVE	42616-131-000	2	
24-2	PLAIN WASHER	94101-1443030-C	2	φ14.1xφ43x3
24-3	INSERT LOCK NUT	90352-14000-C	2	M14
24-4	COTTER PIN	94201-32320	2	3.2x320
24-5	RUBBER CAP	42730-151-000	2	
24-6	WASHER	15152202	2	14x26x1.6

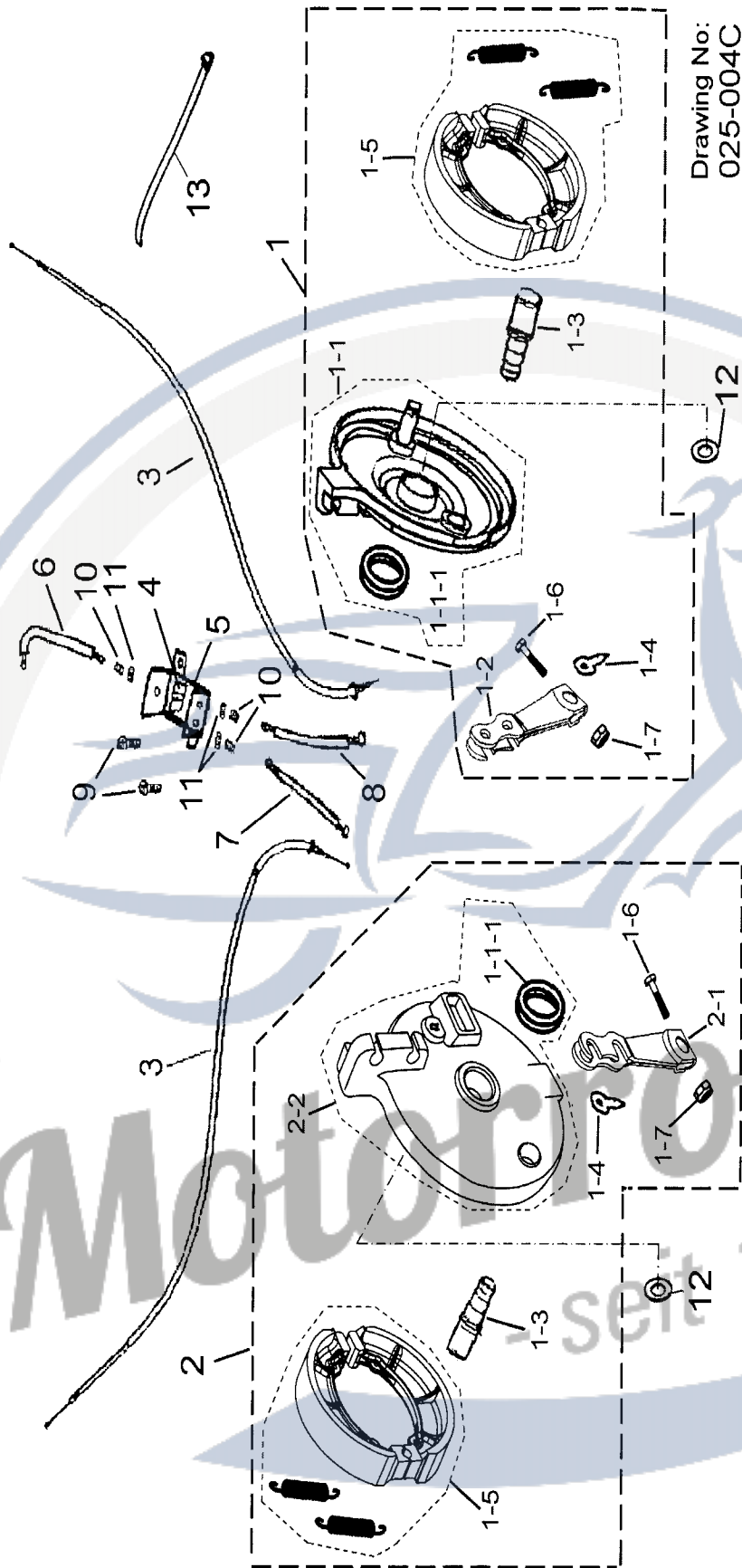

P/N	DESCRIPTION	PART NO.	Q'TY	REMARK
25-1	FRONT BRAKE PLATE ASS'Y (L)	45009-159-001	1	
25-1-1	FRONT BRAKE PLATE (L)	45010-156-002	1	
25-1-1-1	OIL SEAL	96500-4052060	2	

25-1-2	FRONT BRAKE ARM (L)	45410-159-000	1	
25-1-3	FRONT BRAKE CAM SHAFT	45141-156-000	2	
25-1-4	BRAKE GUIDE	45142-156-000	2	
25-1-5	BRAKE SHOE COMP	43120-111-00C	2	非石棉
25-1-6	HEX BOLT	92000-06030-B	2	M6x30
25-1-7	HEX NUT	94001-06000-C	2	M6
25-2	FRONT BRAKE PLATE ASS'Y (R)	45019-159-001	1	
25-2-1	FRONT BRAKE ARM (R)	45409-159-000	1	
25-2-2	FRONT BRAKE PLATE (R)	45020-156-002	1	
25-3	FRONT BRAKE CABLE	45450204	2	
25-4	CONNECTER WIRE LEVELR	45452-133-001	1	
25-5	CONNECTER WIRE SEAT	45453-133-001	1	
25-6	FRONT PEDAL BRAKE CONNECTED CABLE	45454203	1	
25-7	R.FRONT PEDAL BRAKE CABLE	45455203	1	
25-8	L.FRONT PEDAL BRAKE CABLE	45457203	1	
25-9	FLAT HEAD PHILLIPS BOLT	93902-06008-B	2	M6x8
25-10	INSERT BOLT	45421-133-000	3	
25-11	INSERT LOCK NUT	90353-08000-G	3	
25-12	PLAIN WASHER	94101-1722010-K	2	φ17.1xφ21.8xt1
25-13	STRAP	90769-111-000	1	

Motorroller.de
- seit 1993 -

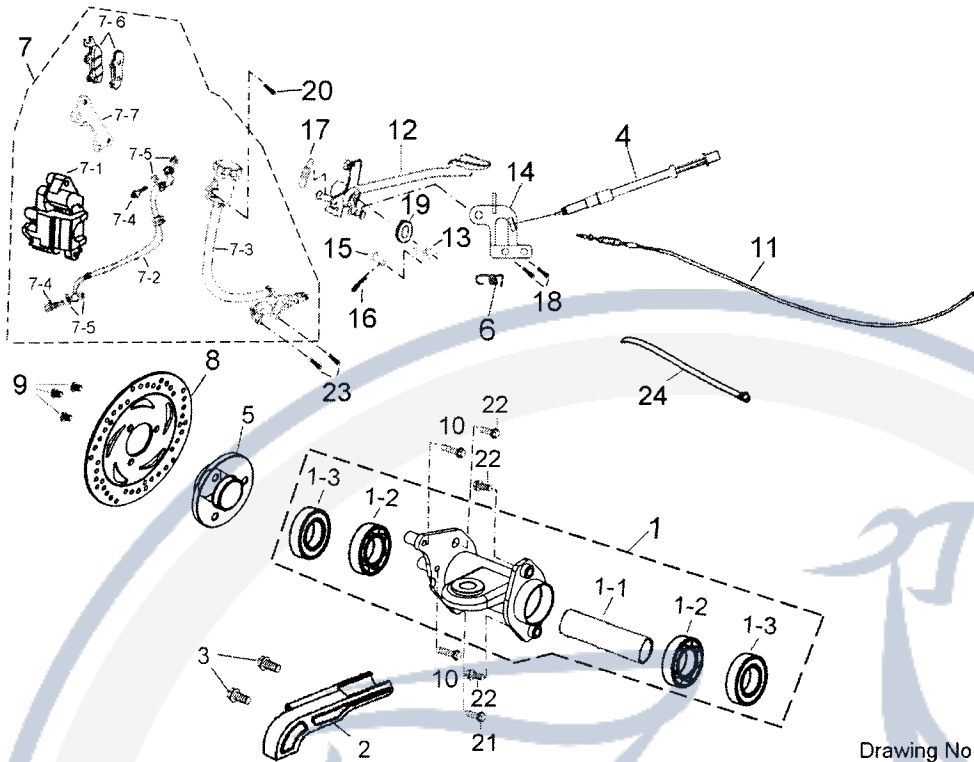

Drawing No:
026-014S

P/N	DESCRIPTION	PART NO.	QTY	REMARK
26-1	REAR WHEEL AXLE FIX SEAT ASS'Y	42803206-A00	1	
26-1-1	SPACER COLLAR	42810-156-001	1	42x35.5x143.2
26-1-2	BEARING	96100-6007ZZ	2	6007ZZ
26-1-3	OIL SEAL	96500-426208	2	42x62-8
26-2	REAR COVER	40550-156-A00	1	
26-3	HEX FLANGE BOLT	96000-08012-K	2	M8x12
26-4	BRAKE LIGHT SWITCH	34912202-000	1	
26-5	BRAKE DISK HOLDER	45490-182-000	1	
26-6	SWITCH SPRING	43421202-000	1	
26-7	REAR HYDRAULIC BARKE ASS'Y	49999202-000	1	
26-7-1	CALIPER ASS'Y	45000-182-000	1	
26-7-2	BRAKE HOSE	45450-182-000	1	
26-7-3	MASTER CYLINDER SUB ASS'Y	45500-182-000	1	
26-7-4	BRAKE HOSE SET BOLT	45456-111-000	2	
26-7-5	PLATE WASHER	94101-1014510-B	4	
26-7-6	REAR BRAKE SHOE	45120-182-000	1	
26-7-7	SUPPORTER	43510201-000	1	
26-8	BRAKE DISK	45010-182-000	1	
26-9	BRAKE DISK HEX SOCKET BOLT	45016-131-00K	3	M10x12
26-10	HEX WASHER FACE BOLT	96000-08038-KL	2	
26-11	REAR BRAKE CABLE	43450182-000	1	

26-12	PENDAL BRAKE LEVER	43456204-000	1	
26-13	HYDRAULIC CYLINDER LEVER	43457201-000	1	
26-14	REAR BRAKE CABLE FIXED HOLDER	50357202-000	1	
26-15	PARALLEL PIN	94302-07018	1	
26-16	COTTER PIN	94203-12200	1	
26-17	SPRING	43421201-000	1	
26-18	HEX BOLT WITH SPRING WASHER	92001-08014-KL	2	M8x14
26-19	WAVE WASHER	15151201-000	1	12x21x0.5
26-20	HEX WASHER FACE BOLT	96000-06012-10K	1	M6x12
26-21	HEX WASHER FACE BOLT	96000-12028-CL	1	M12x28
26-22	HEX FLANGE BOLT	96000-12032-CL	3	M12x1.25x32
26-23	HEX BOLT WITH SPRING WASHER	92001-08020-KL	2	M8x20
26-24	STRAP	90768-151-000	1	

Motorroller.de
- seit 1993 -

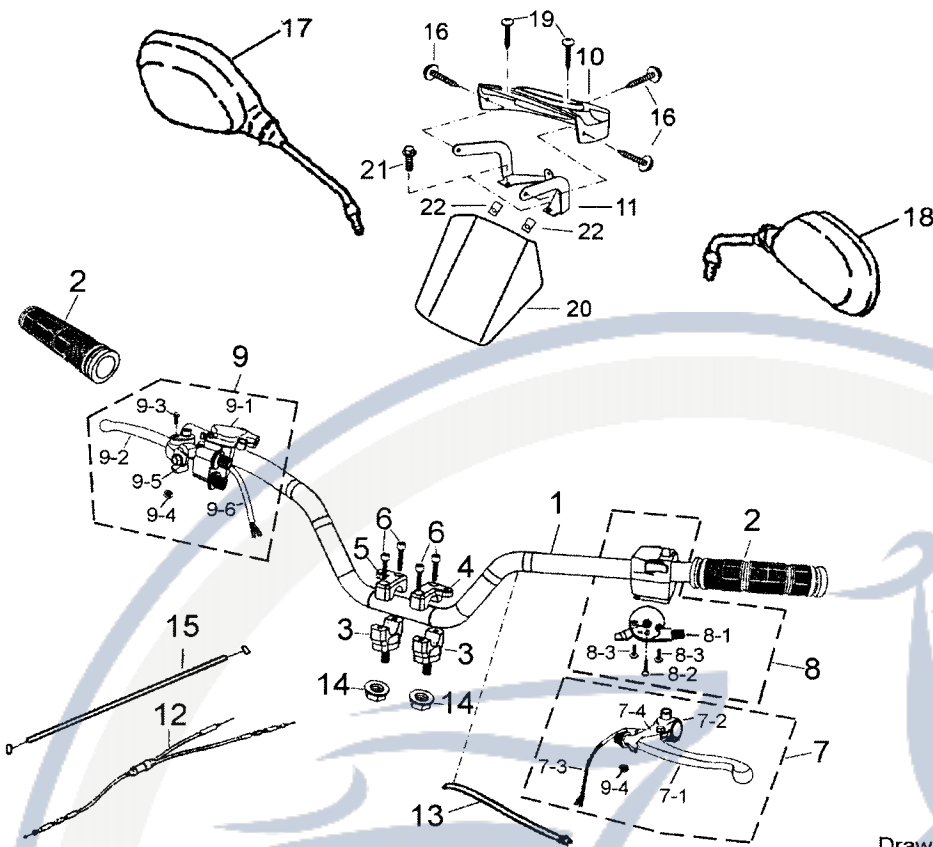

Drawing No:
027-015S

P/N	DESCRIPTION	PART NO.	Q'TY	REMARK
27-1	HANDLE BAR COMP	53100-182-A00	1	
27-2	HANDLE GRIP	53167201--01	2	
27-3	HANDLE BAR CLAMP SADDLE	53200-131-000	2	
27-4	HANDLE BAR CLAMP COVER (A)	53210-131-000	1	
27-5	HANDLE BAR CLAMP COVER (B)	53220-131-000	1	
27-6	HEX SOCKET BOLT	91000-06025-K	4	M6x25
27-7	LEFT LEVER ASS'Y	53171204--01	1	
27-7-1	L. SIDE LEVER	53178-131-000	1	
27-7-2	LEFT LEVEL FIXER	53170201	1	
27-7-3	BRAKE SENSOR SWITCH CABLE (L)	53173-131-000	1	
27-7-4	L.LEVER SET BOLT	90116-131-000	1	M6x23
27-8	L. SWITCH ASS'Y	35151204	1	
27-8-1	MANUAL CHOKE ASS'Y	35160-151-000	1	
27-8-2	PAN PHILLIPS BOLT	93500-06008-K	1	
27-8-3	PAN PHILLIPS BOLT	93100-03004-B	2	
27-9	RIGHT LEVER ASS'Y	53172201	1	
27-9-1	R. SIDE LEVER SEAT	53176201	1	
27-9-2	R. SIDE LEVELR	53175-180-000	1	
27-9-3	RIGHT LEVER SET BOLT	90115-131-000	1	M6x23
27-9-4	NYLON INSERT LOCK NUT	90350-06000-K	2	M6
27-9-5	CABLE STABILIZER	53177-131-000	1	

27-9-6	BRAKE SENSOR SWITCH CABLE (R)	53174201	1	
27-10	HANDLE BAR UPPER POD	64211-181-000	1	
27-11	PROTECT COVER FIX PLATE	53310-181-00A	1	
27-12	THROTTLE CABLE	17910-182-001	1	
27-13	STRAP	90768-151-000	1	
27-14	NYLON INSERT LOCK NUT	90350-10000-C	2	M10
27-15	CHOKE WIRE	17920-182-000	1	
27-16	PAN PHILLIPS BOLT	93100-05016-K	3	M5x16
27-17	R.BACK VIEW MIRROR	88110204	1	
27-18	L.BACK VIEW MIRROR	88120201-001	1	
27-19	TAPPING SCREW TRUSS HEAD PHILLIPS	93903-04012-K	2	M4x12
27-20	SUNSHINY HOOD	64212-182-000	1	
27-21	HEX WASHER FACE BOLT	96000-06012-10K	2	M6x12
27-22	U PLATE NUT	90345-04000-2T	2	

Motorroller.de
- seit 1993 -

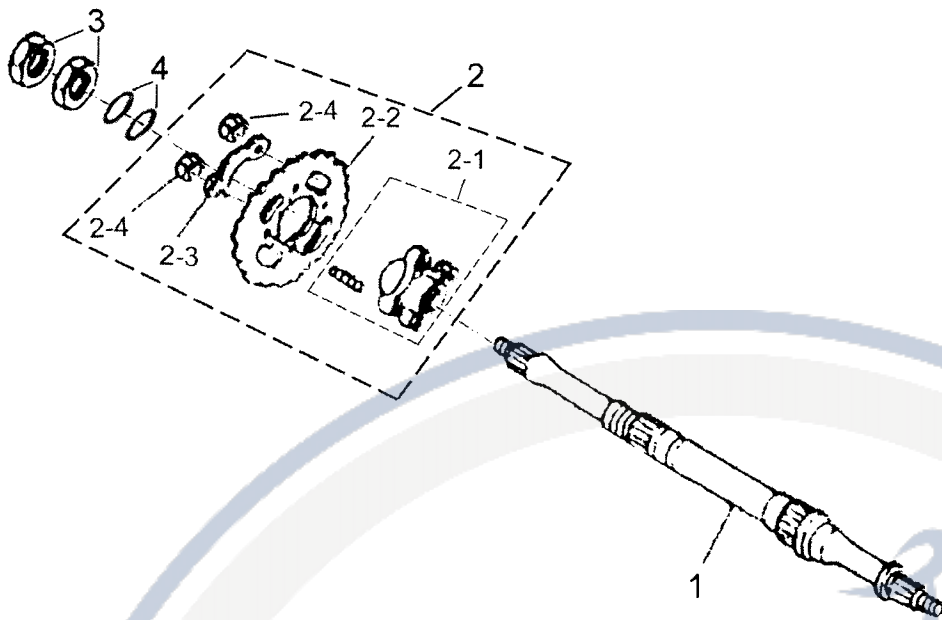

Drawing No:
028-008

P/N	DESCRIPTION	PART NO.	Q'TY	REMARK
28-1	REAR AXLE	97000-158-000	1	
28-2	FINAL DRIVE SPROCKET ASS'Y	41220-156-000	1	
28-2-1	FINAL DRIVE SPROCKET HOLDER SET	41210-156-000	1	
28-2-2	FINAL DRIVE SPROCKET	41201-156-000	1	32T 520
28-2-3	FINAL DRIVE SPROCKET WASHER	41202-156-000	2	
28-2-4	HEX NUT	94002-10000-C	4	M10x1.25-17
28-3	HEX NUT	94001-33000-K	2	M33x1.5
28-4	WASHER	15152204	2	33x45x1.2

Motorroller.de
- seit 1993 -

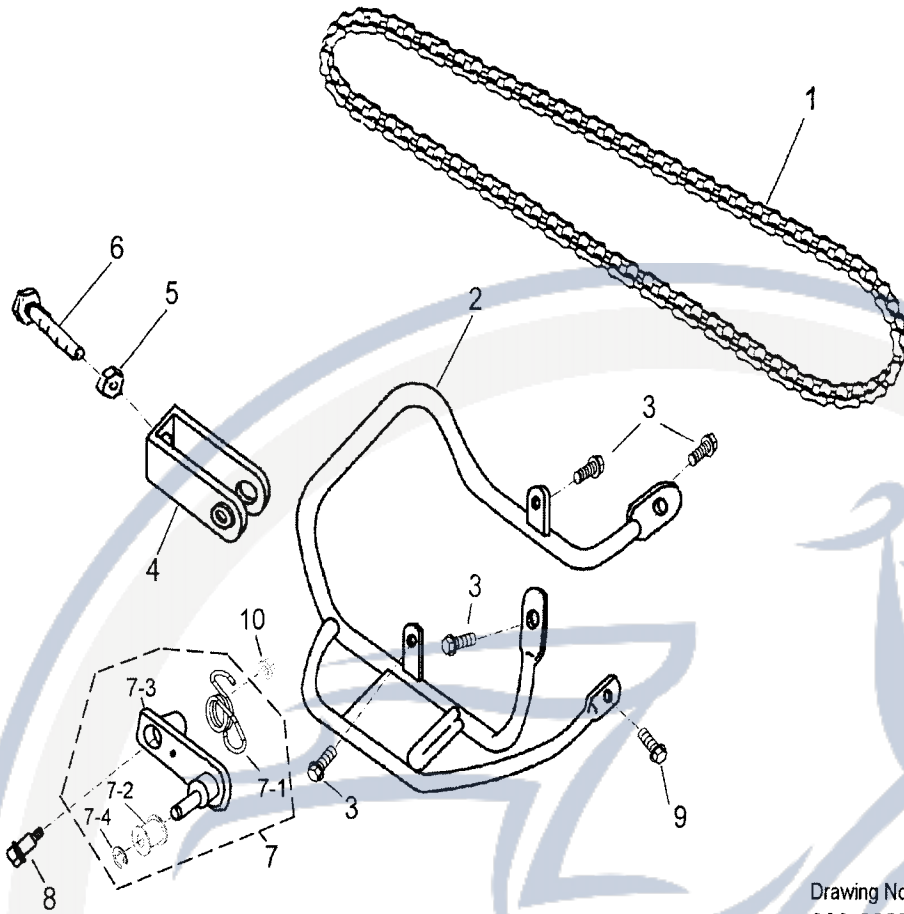

Drawing No:
029-002P

P/N	DESCRIPTION	PART NO.	Q'TY	REMARK
29-1	PRIVE CHAIN ASS'Y	40530-159-001	1	520 ; 72
29-2	PROTECT COVER	40520-182-A00	1	
29-3	HEX FLANGE BOLT	96000-08016-K	4	M8x16
29-4	ADJUSTER , CHAIN	40543-156-000	1	
29-5	HEX FLANGE NUT	94050-08000-C	1	M8x1.25
29-6	HEX BOLT	92000-08060-B	1	M8x60
29-7	CHAIN SUPPORTER ASS'Y	40540-156-004	1	
29-7-1	RETURN SPRING	40541201-000	1	
29-7-2	PLASTIC ROLLER	40545201-000	1	
29-7-3	CHAIN SUPPORT BRACKET	40539202	1	
29-7-4	E-RING	94513-1020100	1	
29-8	HEX FLANGE BOLT	90108-153-000	1	
29-9	HEX FLANGE BOLT	96000-08014-K	1	M8X14
29-10	HEX NUT WITH SERRATION	90350-08000-UK	1	

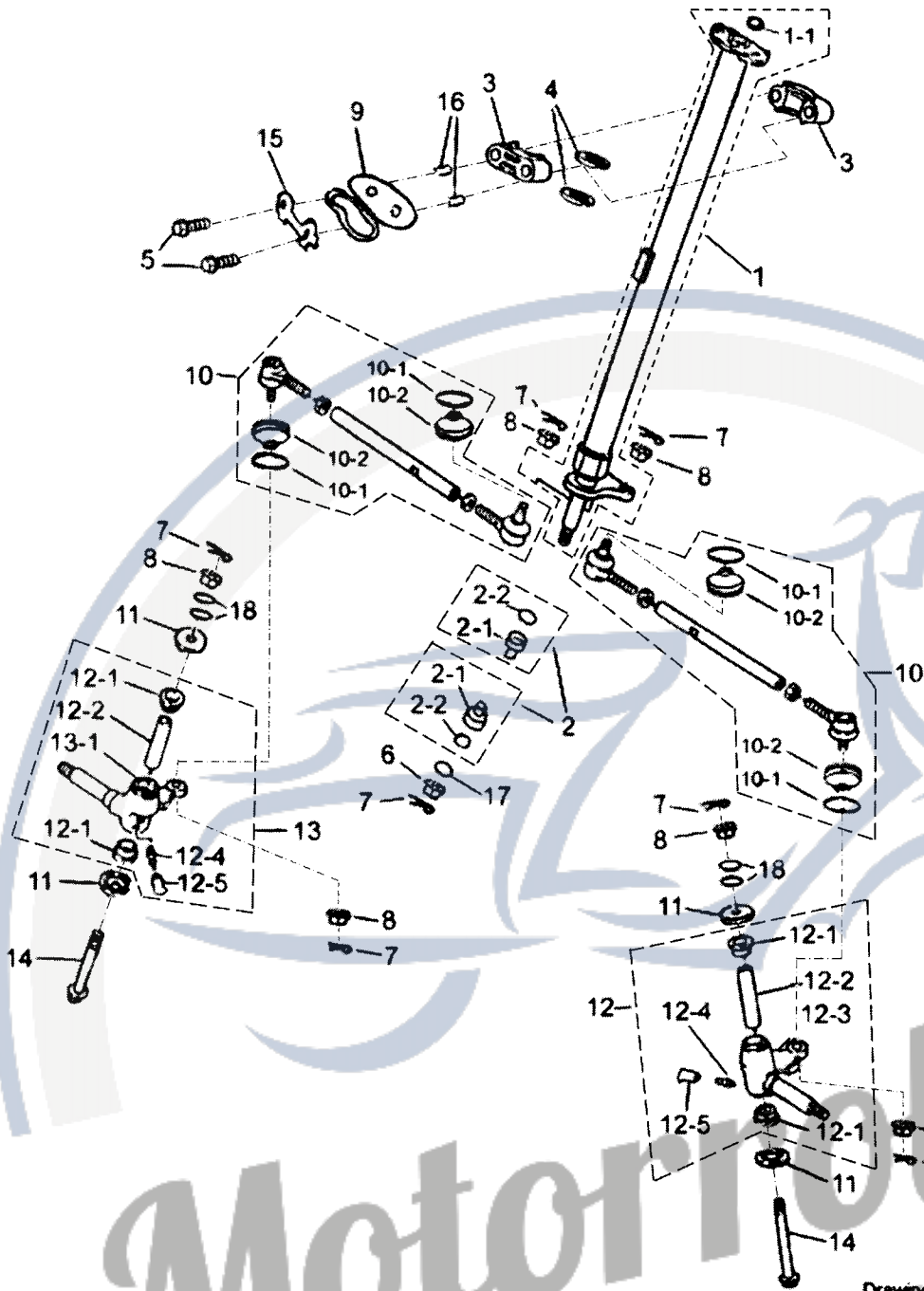

Drawing No:
030-006E

P/N	DESCRIPTION	PART NO.	Q'TY	REMARK
30-1	STEERING SHAFT	51107205-A00	1	鈦銀
30-1-1	RUBBER CAP	19611-156-000	1	
30-2	STEERING BEARING SEAT SET	51115-156-001	2	
30-2-1	STEERING BEARING SEAT	51111-156-000	2	
30-2-2	O-RING	91322-156-000	2	15x2.5
30-3	STEERING SHAFT HOLD	53500-156-000	2	
30-4	STEERING SHAFT OIL SEAL	51220-156-000	2	31.8x37.8x4 3878#
30-5	HEX BOLT	92000-08060-B	2	M8x60
30-6	HEX FLANGE NUT WITH SERRATION	90350-10000-UC	1	M10x1.25
30-7	COTTER PIN	94201-24190	7	3/32x3/4
30-8	INSERT LOCK NUT	90352-10000-C	6	M10

30-9	CABLE FIX SEAT	51318-156-000	1	
30-10(OLD)	STEERING TIE-ROD ASS'Y	53410207-01	2	
30-10	STEERING TIE-ROD ASS'Y	53410202	2	
30-10-1	TIE RING	94514201-000	4	
30-10-2	RUBBER GROMMET	92423201-000	4	
30-11	DUST COVER	52424-156-000	4	
30-12	KNUCKLE SET (L)	51325202	1	
30-12-1	KNUCKLE HOLD	51315-156-000	4	
30-12-2	SPACER RING	51316-156-000	2	10.5x17x73.5
30-12-3	KNUCKLE (L)	51310202	1	
30-12-4	GREASE VALVE	51300-131-000	2	
30-12-5	GREASE VALVE RUBBER CAP	51301-131-000	2	
30-13	KNUCKLE SET (R)	51330202	1	
30-13-1	KNUCKLE (R)	51320202	1	
30-14	HEX FLANGE BOLT WITH HOLD	96200-10105-K	2	10x105
30-15	SPRING WASHER	51319-156-000	1	
30-16	SPACE RING	51317-156-000	2	9x14x42
30-17	COPPER WASHER	94101-1022010-U	1	10x22x1
30-18	WASHER	15152205	4	10x20x1

Motorroller.de
- seit 1993 -

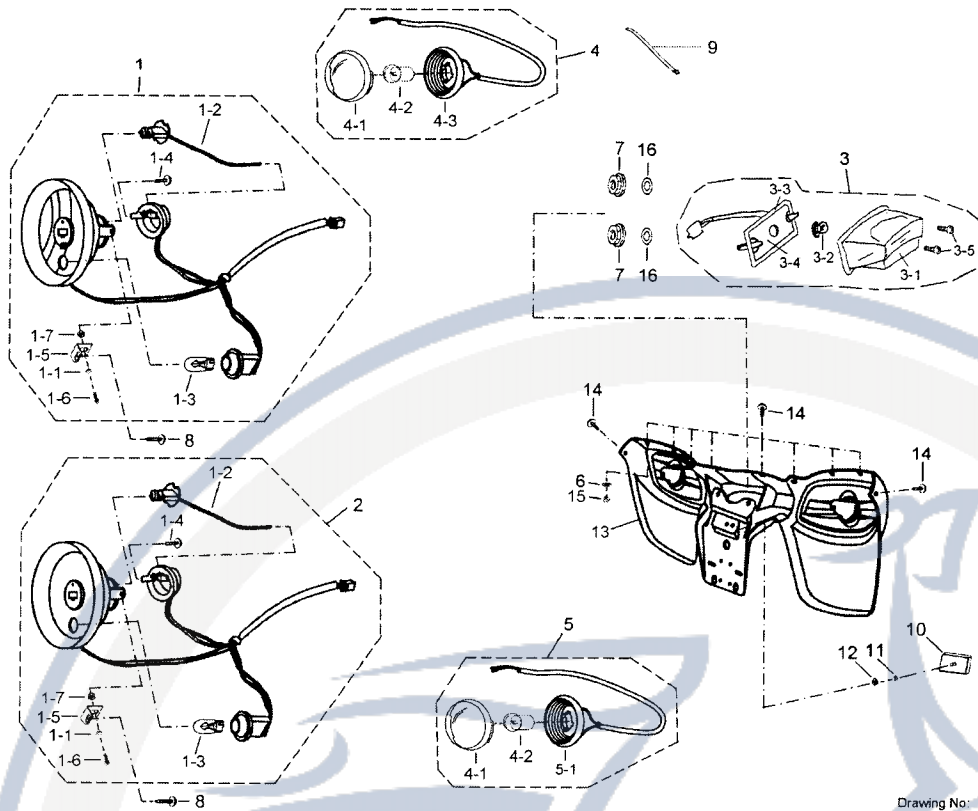

Drawing No:
031-026F

P/N	DESCRIPTION	PART NO.	Q'TY	REMARK
31-1	LOW BEAM ASS'Y	33100203-000	1	
31-1-1	SPRING WASHER	94111-0610010	4	6x10x1
31-1-2	BULB	34901201-000	2	12V/35W
31-1-3	POSITION LIGHT BULB	34909201-000	2	12V W5W
31-1-4	PAN PHILLIPS BOLT	93100-03006-B	2	M3x6
31-1-5	FIX PLATE	33122201-000	4	
31-1-6	HEX BOLT	92000-06012-K	4	M6x12
31-1-7	HEX NUT	94001-06000-K	4	M6
31-2	HIGH BEAM ASS'Y	33100204-000	1	
31-3	TAIL LIGHT ASS'Y	33700-131-00A	1	
31-3-1	TAIL LIGHT LENS	33702-131-00A	1	
31-3-2	TAIL LIGHT BULB	33906-116-00A	1	E-MARK
31-3-3	WATERPROOF GASKET	33716-131-000	1	
31-3-4	REAR LIGHT SOCKET	33711-131-00A	1	E-MARK
31-3-5	PAN PHILLIPS BOLT	93500-04035-SUS	2	M4x35
31-4	RIGHT SINGAL ASS'Y	33400-182-000	2	
31-4-1	SIGNAL COVER	33402201-000	4	
31-4-2	BULB	33905201-000	4	12V/10W
31-4-3	RIGHT SINGAL REFLECTOR	33401201-000	2	
31-5	LEFT SINGAL ASS'Y	33450-182-000	2	
31-5-1	LEFT SINGAL REFLECTOR	33451201-000	2	
31-6	PLAIN WASHER	94101-0514010-K	10	ψ5xψ14x1mm

15.11.2004

31-7	HEX FLANGE NUT	94050-06000-C	2	M6
31-8	TAPPING SCREW	93903-05012-K	4	M5x12
31-9	STRAP	90768-151-000	2	
31-10	REFLECCTOR	33741-131-000	1	
31-11	PLAIN WASHER	94101-0519010-K	1	
31-12	HEX FLANGE NUT	94050-05000-C	1	
31-13	LICENSE PLATE	33708-182-000	1	黑色/PP加鉛
31-14	PAN PHILLIPS BOLT	93100-05016-K	10	M5x16
31-15	NYLON INSERT LOCK NUT	90350-05000-K	10	M5
31-16	PLAIN WASHER	94101-0619010-C	2	

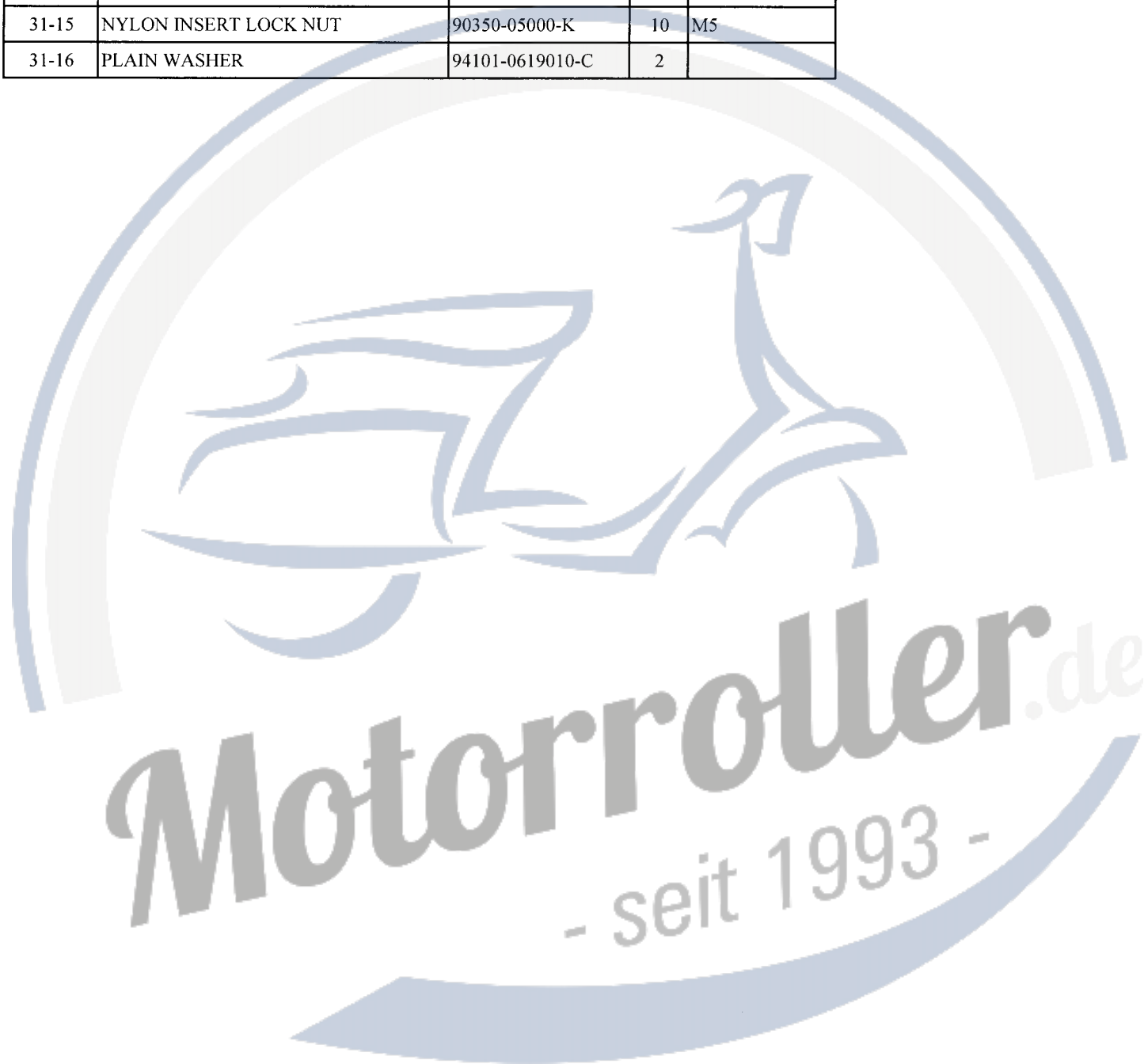

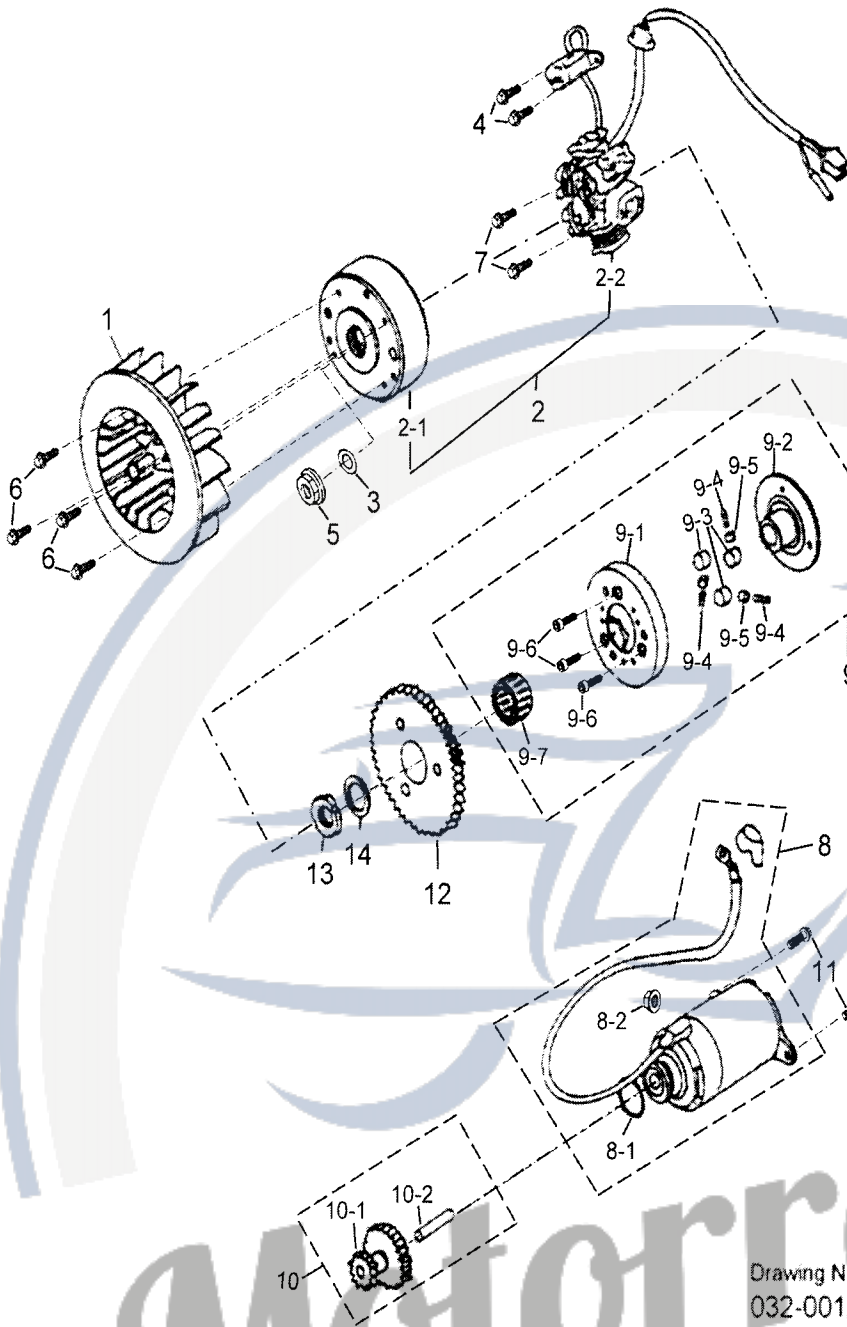

Drawing No.
032-001A

P/N	DESCRIPTION	PART NO.	Q'TY	REMARK
32-1	FAN	19510-119-000	1	
32-2	GENERATOR ASS'Y	31100204	1	
32-2-1	GENERATOR FACE FLY WHEEL	31110-119-000	1	
32-2-2	STATOR COMP	31120201	1	
32-3	PLAIN WASHER	94101-1225023	1	12x25x2.3
32-4	HEX BOLT	92000-05012-C	2	M5x12
32-5	HEX FLANGE NUT	94050-12000-C	1	M12
32-6	HEX FLANGE BOLT	96000-06018-8C	4	M6x18

32-7	HEX FLANGE BOLT	96000-06020-8C	2	M6x20
32-8	STARTING MOTOR ASS'Y	31200-119-000	1	
32-8-1	OIL RING	91324-119-000	1	24.4x3.1

15.11.2004

32-8-2	HEX FLANGE NUT	94050-06000-C	1	M6
32-9	STARTING CLUTCH ASS'Y	28410-119-001	1	
32-9-1	CLUTCH COVER COMP	28120-119-000	1	
32-9-2	FLANGE STARTING CLUTCH	28125-119-000	1	
32-9-3	CLUTCH ROLLER	28411-119-000	3	
32-9-4	CLUTCH SPRING	28413-119-000	3	
32-9-5	CLUTCH GUIDER	28412-119-000	3	
32-9-6	HEX SOCKET BOLT	91000-06012-C	3	M6x12
32-9-7	NEEDLE BEARING	96200-283217	1	
32-10	GEAR STARTER REDUCTION ASS'Y	28422-119-000	1	
32-10-1	GEAR STARTER REDUCTION	28423-119-000	1	
32-10-2	SHAFT STARTER REDUCTION GEAR	96300-119-000	1	
32-11	HEX FLANGE BOLT	96000-06018-8C	2	M6x18
32-12	GEAR COMP STARTING CLUTCH	28220-119-000	1	
32-13	NUT	94071-22000-0	1	M22
32-14	PLAIN WASHER	94101-2231025	1	22x31x2.5



Motorroller.de
- seit 1993 -

33-15	HEX FLANGE NUT	94050-06000-C	2	M6
33-16	PAN PHILLIPS BOLT WITH WASHER	93501-03010-K	2	M3x10
33-17	PAN PHILLIPS BOLT	93100-05012-K	2	5Mx12
33-18	TOUCH SWITCH	34912203	1	
33-19	REVERSE INDICATOR SWITCH	34913201	1	
33-20	HEX NUT	94001-03000-K	1	M3
33-21	ELECTRIC EQUIPMENT FIXED BOARD	32104201	1	
33-22	PAN PHILLIPS BOLT WITH WASHER	93501-03010-K	1	M3x10
33-23	HEX SOCKET BOLT	91000-05016-K	2	M5x16
33-24	HORN (E-MARK)	38110-119-000	1	
33-25	HEX WASHER FACE BOLT	96000-06012-10K	1	M6x12
33-26	HEX BOLT WITH WASHER	92000-06016-K	2	
33-27	BUSH OF SPARK PLUG CAP	30701201-000	1	
33-28	NYLON INSERT LOCK NUT	90350-04000-K	2	M4
33-29	PLAIN WASHER	94101-0412010-K	2	4x12x1
33-30	SPEEDOMETER FIXED PLATE	37201-159-000	1	
33-31	CABLE SEAT	32107201	2	
33-32	SIGNAL WARNER	38302-133-001	1	
33-33	SPEEDOMETER ASS'Y	37200202-002	1	
33-33-1	MAIN UNIT OF SPEEDOMETER	37205202-002	1	
33-33-2	SENSOR OF SPEEDOMETER	37202-182-000	1	
33-33-3	MAGNET	37203-159-000	1	
33-34	PAN PHILLIPS BOLT	93100-04016-K	2	M4x16
33-35	MAIN WIRE (FRONT)	32103201	1	
33-35-1	FUSE	32106201-000	1	15A
33-36	MAIN WIRE (BACK)	32101201	1	
33-37	BATTERY WIRE	32102182	1	

Motorroller.de
- seit 1993 -

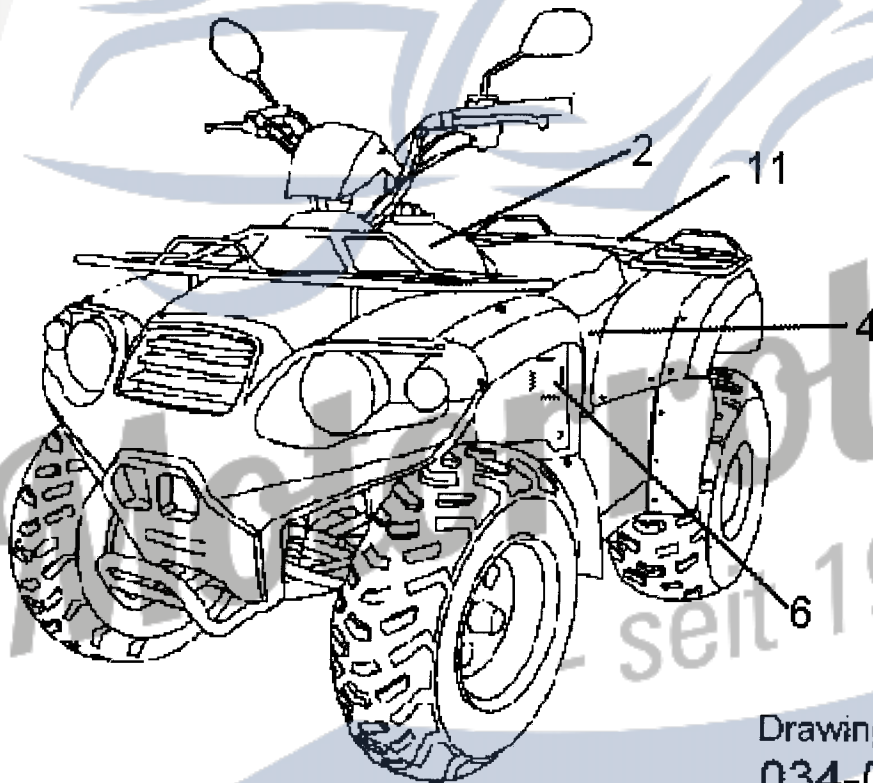
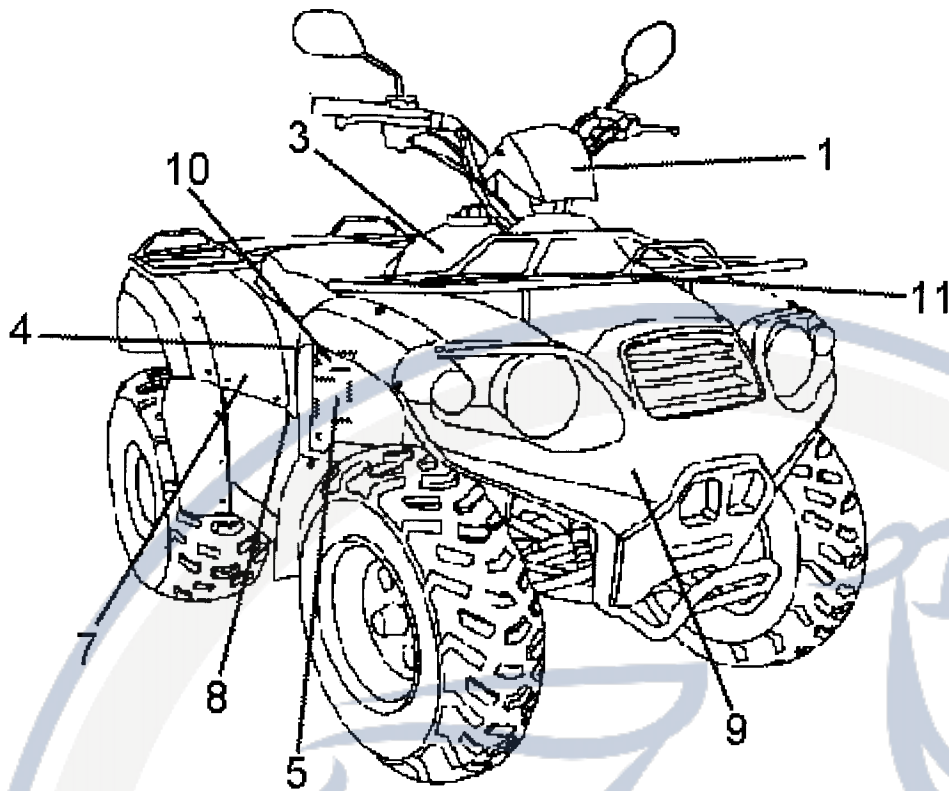

Drawing:
034-C

P/N	DESCRIPTION	PART NO.	Q'TY	REMARK
34-1	DECAL-AEON LOGO	87711-162-000	1	
34-2	DECAL - FUEL TANK (L)	87721209	1	
34-3	DECAL-FUEL TANK (R)	87720209	1	
34-4	DECAL - OVERLAND 180	87716208	2	
34-5	DECAL - WARNING (Y-16)	87751-159-000	1	(Y-16)
34-6	DECAL - WARNING	87752-159-000	1	

34-7	DECAL CHAIN TENSIONING	87758-156-001	1	
34-8	DECAL GEAR SHIFTING	87759-156-000	1	
34-9	DECAL-VIN CODE	87771-074029	1	
34-10	DECAL-REVERSE GEAR WARING	87754-156-000	1	
34-11	DECAL CARRIER WARNING	87769-131-000	2	

15.11.2004



OWNER — 1

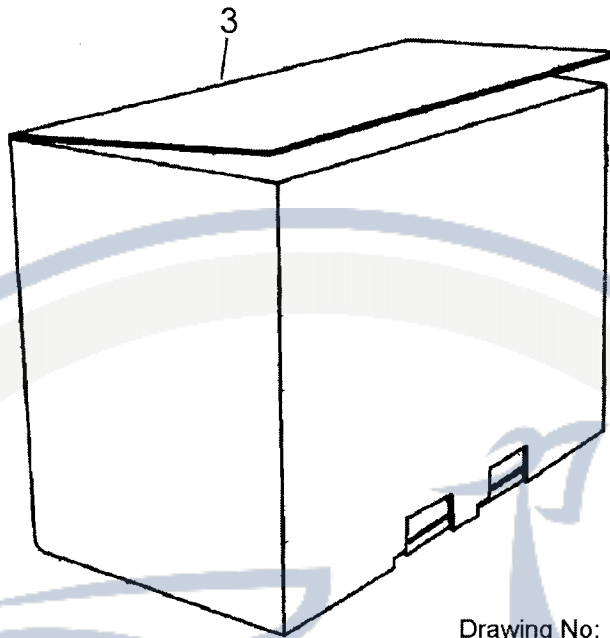
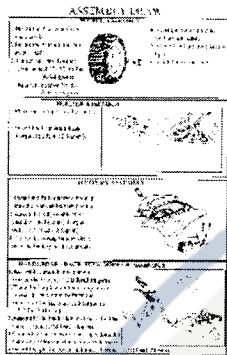

Drawing No:
035-030

P/N	DESCRIPTION	PART NO.	Q'TY	REMARK
35-1	OWNERS MANUAL	OWNER-180	1	
35-2	ASSEMBLY DRAW	ASS-204	1	
35-3	PACKING	89005204-000	1	1710x1010x790mm

Motorroller.de
- seit 1993 -

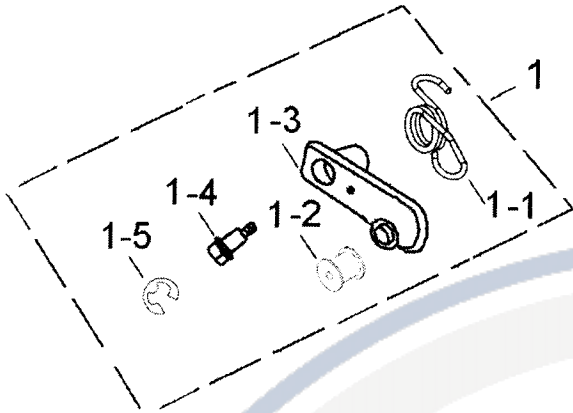

Drawing No:
036-019

P/N	DESCRIPTION	PART NO.	Q'TY	REMARK
36-1	CHAIN SUPPORTER KIT	95400202	1	
36-1-1	RETURN SPRING	40541-156-002	1	
36-1-2	PLASTIC ROLLER	40545201-000	1	
36-1-3	CHAIN SUPPORT BRACKET	40539202	1	
36-1-4	HEX FLANGE BOLT	90108-153-000	1	
36-1-5	E RING	94513-1020100	1	

Motorroller.de
- seit 1993 -