

D-1 FAN COVER,SHROUD CXG,ÜÜLD

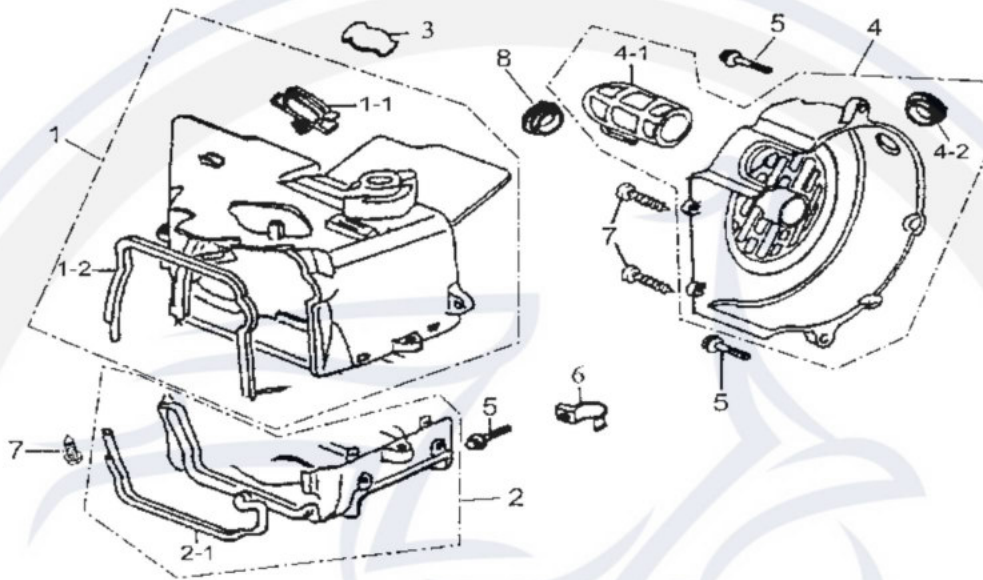

P/N	DESCRIPTION	PART NO.	Q'TY	REMARK
1-1	SHROUD - UPPER	19623-119-000	1	
1-1-1	BREATHER TUBE CLAMPER	11384-119-000	1	
1-1-2	SHROUD SEAL UPPER	19635-119-000	1	
1-2	SHROUD-LOWER	19621-119-000	1	
1-2-1	SHROUD SEAL-LOWER	19625-119-000	1	
1-3	RUBBER BUNG B	19633-119-000	1	
1-4	FAN COVER ASS'Y	19610-119-000	1	
1-4-1	CARBURETOR COOLING DUCT	19615-119-000	1	
1-4-2	RUBBER BUNG	17529-119*000	1	
1-5	HEX FLANGE	96000-06025-8C	3	M6'25
1-6	CLAMPER CARB DRAIN TUBE	11353-119-000	1	
1-7	CROSS TAPPING SCREW	93904-05016-K	4	5'16
1-8	RUBBER CAP	19611-156-000	1	

D-2 CYLINDER HEAD COVER

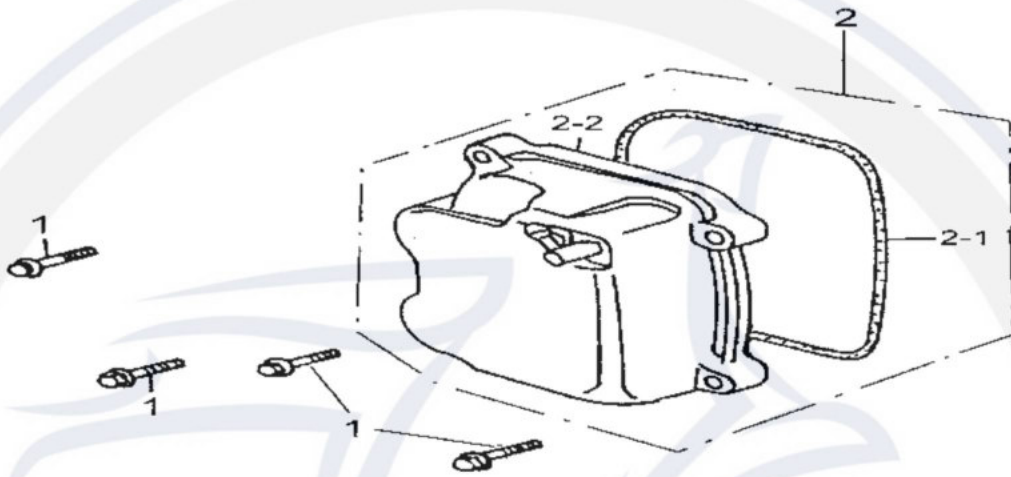

P/N	DESCRIPTION	PART NO.	Q'TY	REMARK
2-1	HEX FLANGE BOLT	96000-06025-8C	4	IVT6 '25
2-2	CYLINDER HEAD COVER ASS'Y	12310-158-000	1	
2-2-1	CYLINDER HEAD COVER GASKET	12391-119-000	1	
2-2-2	CYLINDER HEAD COVER	12309-158-000	1	

D-3 CAMSHAFTGVALVENCYLINDER HEAD □□,□□

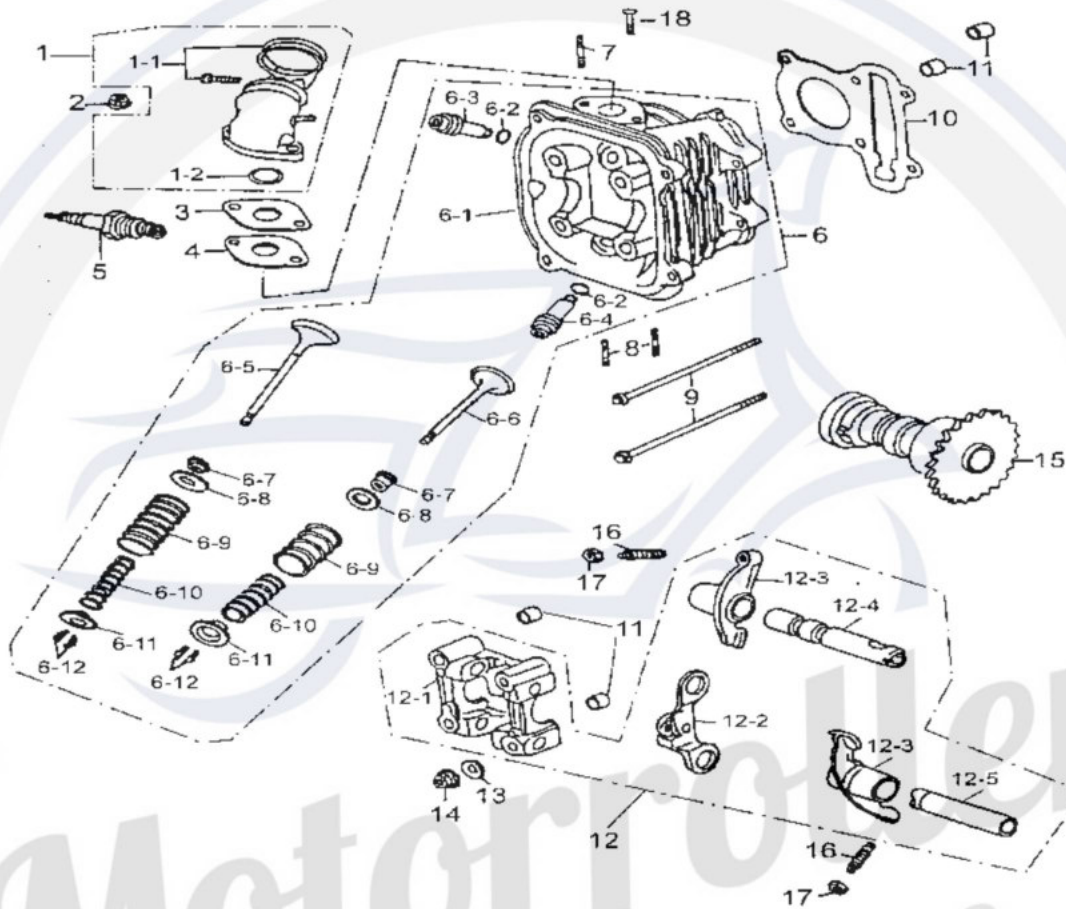

P/N	DESCRIPTION	PART NO.	Q'TY	REMARK
3-1	INAKE MAIN FOLD	17100-119-000	1	
3-1-1	BAND INSULATOR	14111-119-000	1	
3-1-2	OIL-RING	91327-119-000	1	9.5 '1.6
3-2	HEX FLANGE NUT	94050-06000-C	2	M6
3-3	CARBURETOR INSULATOR	16213-119-000	1	
3-4	CARBURETOR INSULATOR GASKET	16229-119-000	1	
3-5	SPARK PLUG	98076-119-OOA	1	CR7HSA
3-6	CYLINDER HEAD ASS'Y	12200-158-000	1	
3-6-1	CYLINDER HEAD	12201-158-000	1	◆
3-6-2	OIL-RING	91309-119-000	2	27'2
3-6-3	IN.GUIDE VALVE	12204-122-000	1	
3-6-4	EX.GUIDE VALVE	12206-122-000	1	
3-6-5	EX. VALVE	14721-122-000	1	
3-6-6	IN. VALVE	14711-122-000	■ 1	
3-6-7	VALVE STEM SEAL	12209-119-000	2	
3-6-8	SEAT VALVE SPRING OUTER	14775-119-000	2	
3-6-9	VALVE OUTER SPRING	14751-119-000	2	
3-6-10	VALVE INNER SPRING	14761-119-000	2	
3-6-11	VALVE SPRING RETAINER	14771-119-000	2	
3-6-12	COTTER VALVE	14781-119-000	4	
3-7	STUD BOLT	91001-06062-C	2	M6'62

Aktuelle Preise erfahren sie auf www.motorroller.de

3-8	STUD BOLT	91001-08032-C	2	M8'32
3-9	HEX FLANGE BOLT	96000-06100-08-C	2	M6'100
3-10	CYLINDER HEAD GASKET	12251-158-000	1	
3-11	DOWEL PIN	94301-10140	4	10'14
3-12	CAM SHAFT HOLDER ASSY	12210-158-000	1	
3-12-1	CAMSHAFT HOLDER	12211-158-000	1	
3-12-2	PLATE COMP STOPPER	14456-119-000	1	
3-12-3	ARM VALVE ROCKER	14431-119-000	2	
3-12-4	SHAFT COMP IN ROCKER ARM	14452-158-000	1	
3-12-5	SHAFT EX ROCKER ARM	14453-158-000	1	
3-13	COPPER PLAIN WASHER	94101-0818023-U	4	8'18'2,3
3-14	HEX FLANGE NUT	94050-08000-C	4	M8
3-15	CAMSHAFT COMP	14400-122-000	1	
3-16	SCREW TAPPEL ADJUSTING	90012-119-000	2	
3-17	TAPPET ADJUSTING	90206-119-000	2	

Motorroller.de
- seit 1993 -

D-4 CAM CHAIN,TENSIONER □□□,□□□

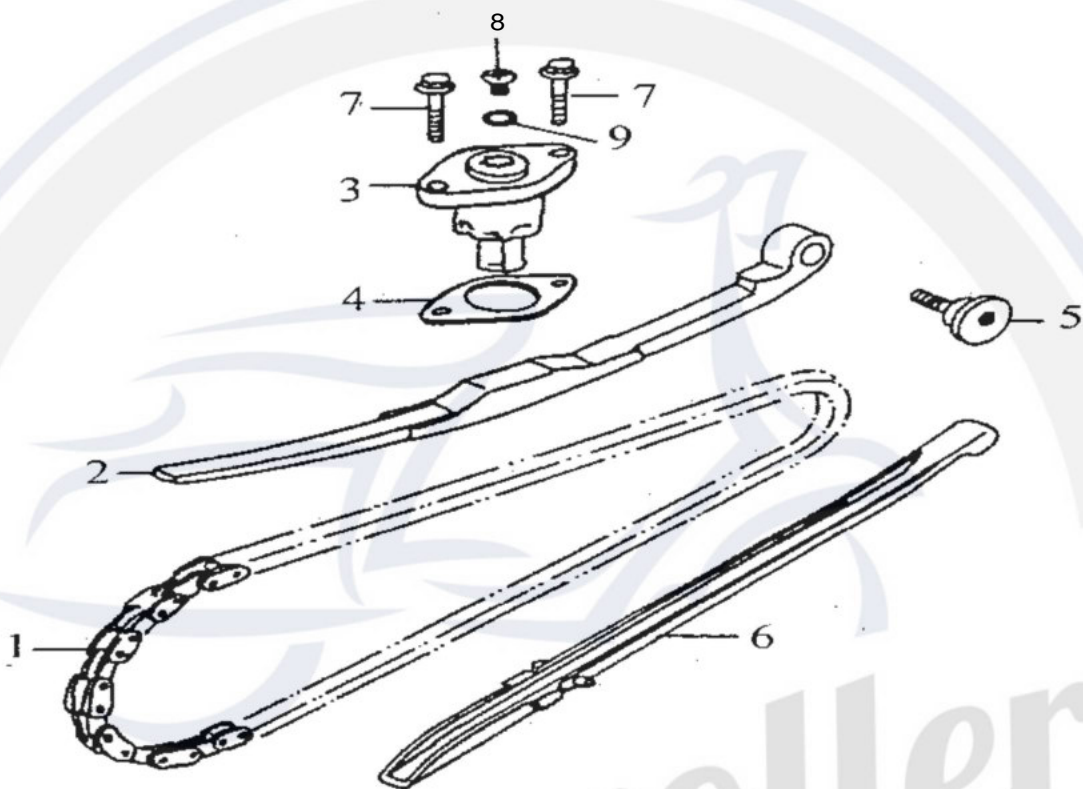

P/N	DESCRIPTION	PART NO.	Q'TY	REMARK
4-1	CHAIN CAM	14401-119-000	1	
4-2	TENSIONER CAM CHAIN	14550-119-000	1	
4-3	LIFTER TENSIONER LIFTER	14521-119-000	1	
4-4	GASKET TENSIONER LIFTER	14523-119-000	1	
4-5	PIVOT CAM CHAIN TENSIONER	14535-119-000	1	M6'22
4-6	GUIDE COMP CAM CHAIN	14500-119-000	1	
4-7	HEX FLANGE BOLT	96000-06022-814-C	2	M6'22
4-8	SCREW,PAN	93000-06006-K	1	M6'6
4-9	OIL-RING	91309-119-000	1	9.5'1.5

D-5 CYLINDER

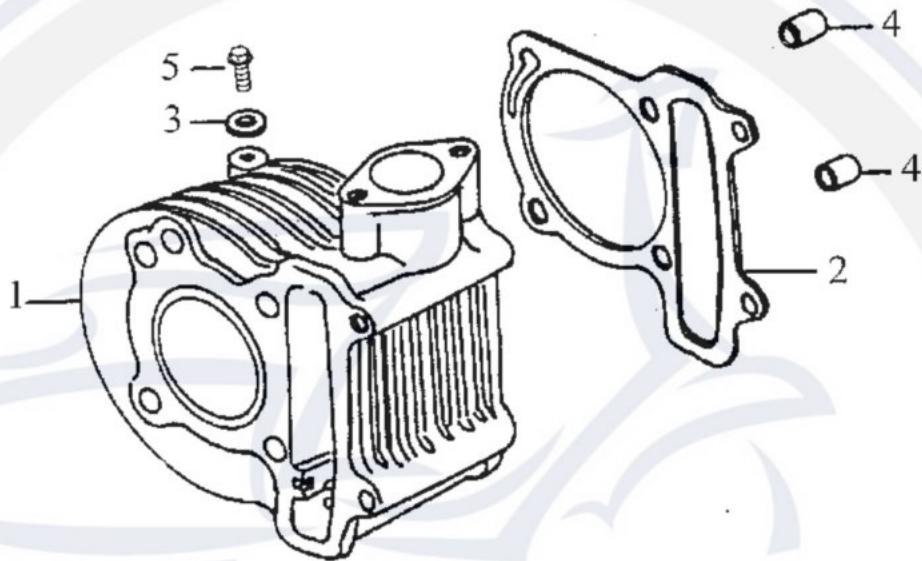

P/N	DESCRIPTION	PART NO.	QTY	REMARK
5-1	CYLINDER	12101-158-000	1	
5-2	CYLINDER GASKET	12191-158-000	1	
5-3	COPPER PLAIN WASHER	94101-0612010-U	1	6.512 1
5-4	DOWEL PIN	94301-10140	2	10'14
5-5	HEX FLANGE BOLT	96000-06012-100	1	M6'12

D-6 RIGHT CRANKCASE COVER

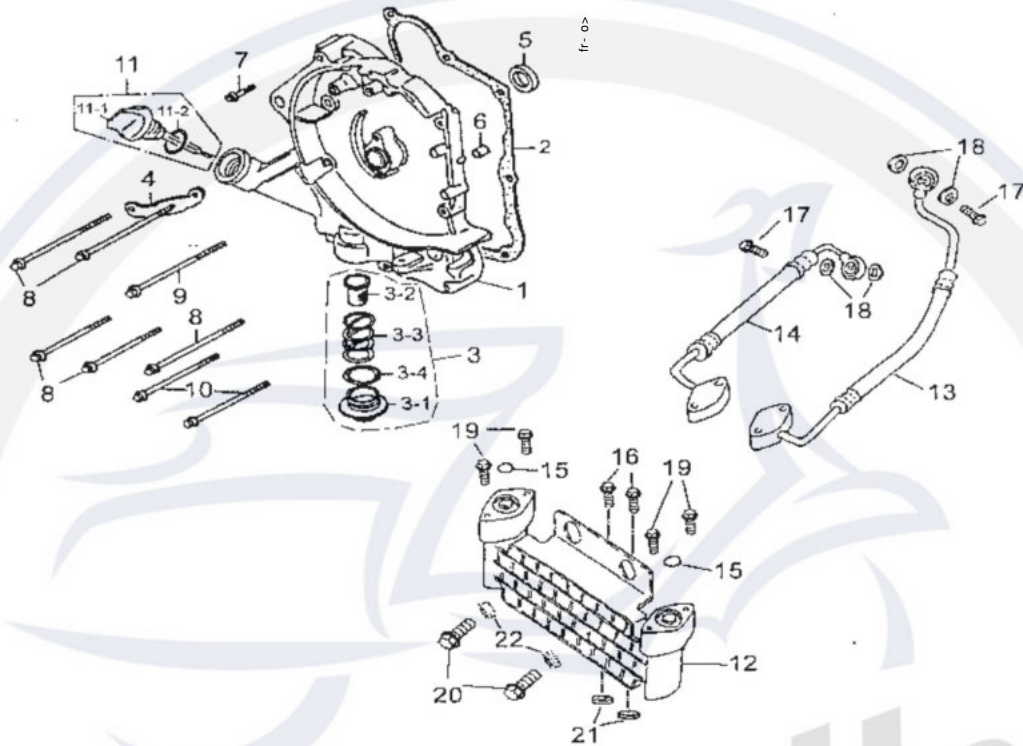

P/N	DESCRIPTION	PART NO.	Q'TY	REMARK
6-1	RIGHT CRANKCASE OVER	11330-156-000	1	
6-2	GASKET R. CRANKCASE COVER	11393-156-000	1	
6-3	SCREEN OIL FILTER ASSY	12361-119-000	1	
6-3-1	CAP TAPPET ADJUSTING HOLE ASS'Y	12360-119-000	1	
6-3-2	SCREEN OIL FILTER	15421-119-000	1	
6-3-3	SPRING OIL FILTER SPRING	15426-119-000	1	
6-3-4	OIL RING	91330-119-000	1	30,8mm
6-4	CLAMPER A.C.GENERATOR CORD	32961-119-000	1	
6-5	OIL SEAL	96500-19305	1	19,8'30'5
6-6	DOWEL PIN	94301-08140	2	8'14
6-7	HEX FLANGE BOLT	96000-06028-8C	1	M6'28
6-8	HEX FLANGE BOLT	96000-06095-8C	5	M6'95
6-9	HEX FLANGE BOLT	96000-06100-8C	1	M6'100
6-10	HEX FLANGE BOLT	96000-06110-8C	2	M6'110
6-11	GAUGE ASS'Y OIL LEVEL	1565A-119-000	1	
6-11-1	GAUGE OIL LEVEL	15650-119-000	1	j
6-11-2	OIL RING	91318-119-000	1	18'3
6-12	RADIATOR	15210-158-000	1	
6-13	LIFE HOSE OUTLET	15230-158-000	1	
6-14	RIGHT HOSE INLET	15220-158-000	1	
6-15	O-RING	91312-111-000	.2	13.8x2.5
6-16	HEX FLANGE BOLT	96000-06012-K	2	M6x12
6-17	OIL TUBE FIXED BOLT	45456-156-000-G	2	M12x1.25
6-18	PLAIN WASHER	94101-1221320-L	4	12x21.3x2
6-19	HEX FLANGE BOLT	96000-06025-K	4	M6x25
6-20	HEX FLANGE BOLT	96000-08012-K	2	M8*12
6-21	SHAKE-PROOF RUBBER WASHER	64320-156-000	2	
6-22	SHAKE-PROOF RUBBER RING	64321-156-000	2	

Aktuelle Preise erfahren sie auf www.motorroller.de

D-7 OIL PUMP

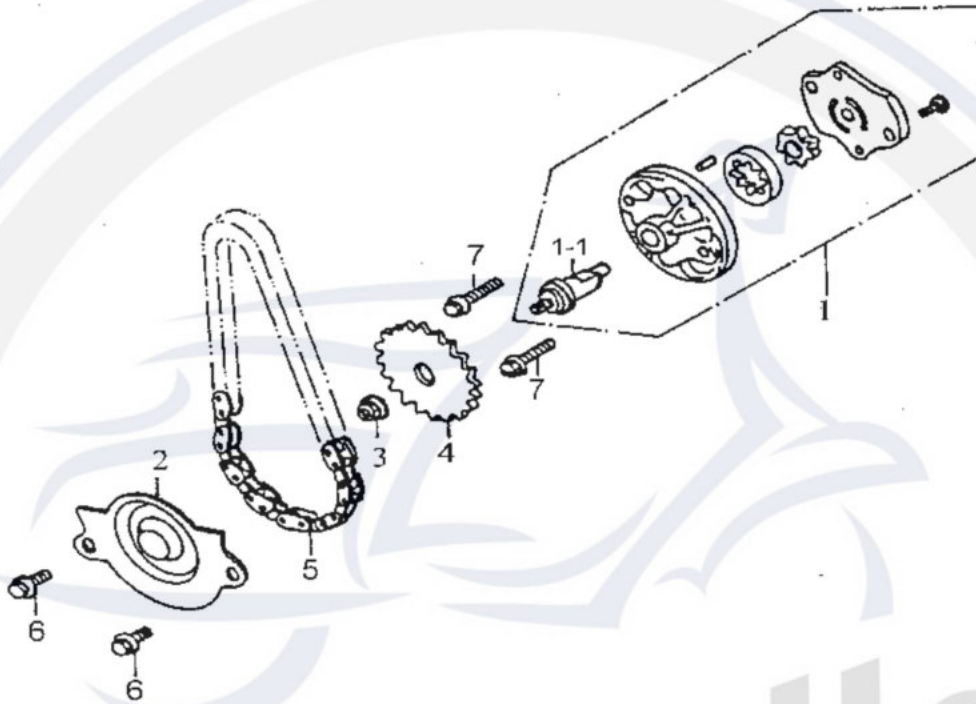

P/N	DESCRIPTION	PART NO.	Q'TY	REMARK
7-1	OIL PUMP	15100-158-000	1	
7-1-i	OIL PUMP PROIMARY AXLE	15131-158-000	1	
7-2	SEPARATOR A OIL	15711-119-000	1	
7-3	HEX FLANGE NUT	94050-06000-C	1	M6
7-4	OIL PUMP DRIVE GEAR	15150-119-000	1	
7-5	CHAIN OIL PUMP	15141-119-000	1	
7-6	HEX FLANGE BOLT	96000-06012-8C	2	M6'12
7-7	PAN BOLT	93902-06030-8C	2	M6'30

D-8 LEFT CRANKCASE COVER

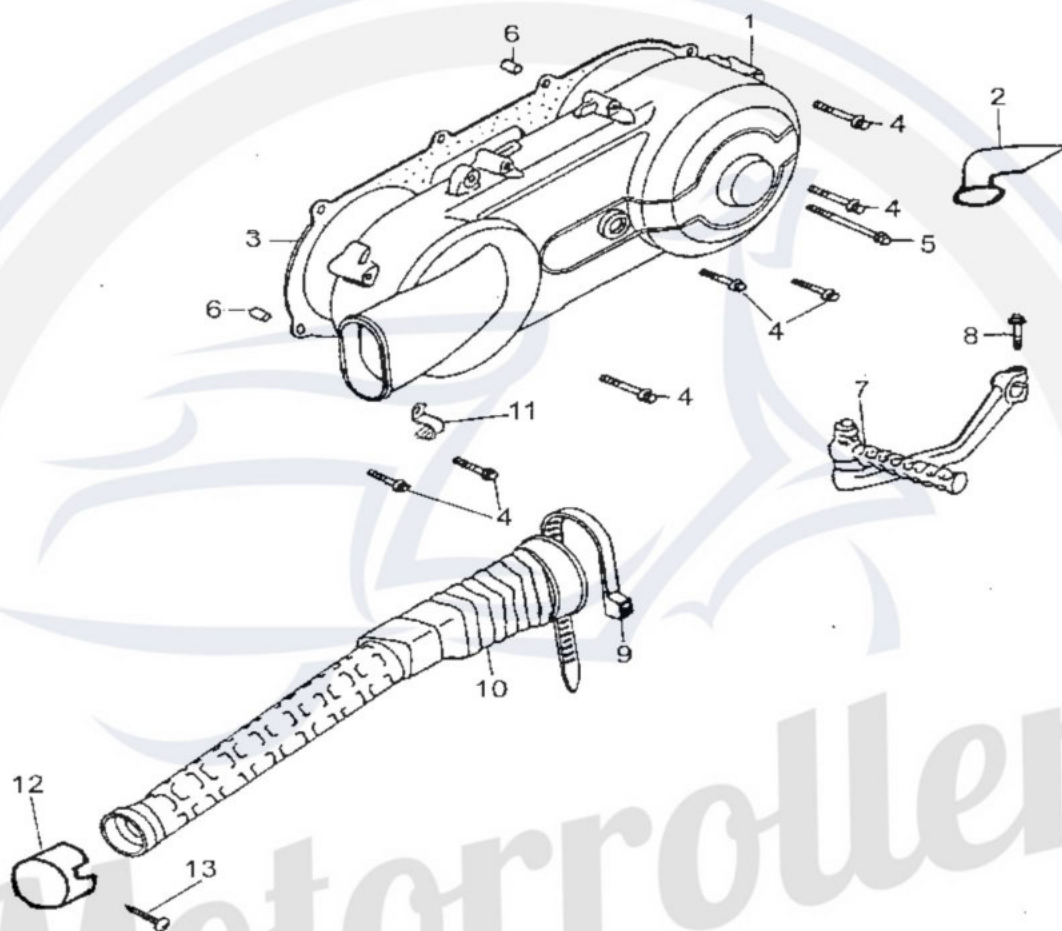

P/N	DESCRIPTION	PART NO.	Q'TY	REMARK
8-1	COVER L	11341-156-000	1	
8-2	CLAMPER THROTTLE CABLE	11211-112-000	1	
8-3	GASKET L COVER	11359-119-000	1	
8-4	HEX FLANGE BOLT	96000-06040-08-C	7	M6'40
8-5	HEX FLANGE BOLT	96000-06100-08-C	1	M6'100
8-6	DOWEL PIN	94301-08140	2	8'14
8-7	ARM ASSY KICK STARTER	28300-156-000	1	
8-8	HEX FLANGE BOLT	96000-06025-K	1	M6'25
8-9	STRAP	90669-119-001	1	D61
8-10	DUCT L. CRANKCASE COVER	11345-119-000	1	
8-11	BREATHER HOSE CLIP	11351-119-000	1	
8-12	DUST PROOF RUBBER	11349-156-000	1	
8-13	TAPPING SCREW	93903-04016-K	1	M4x16

D-9 DRIVE FACE □□□

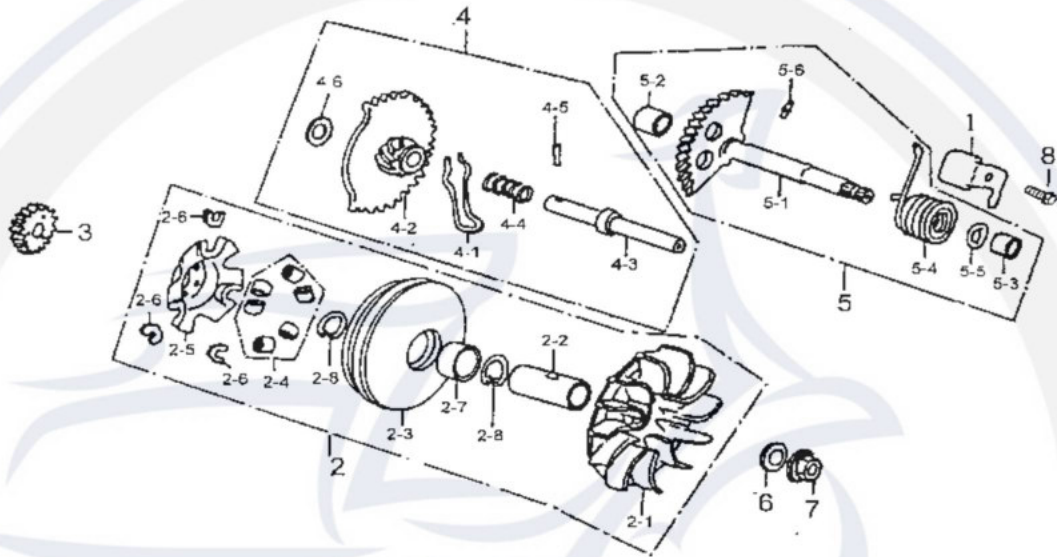

P/N	DESCRIPTION	PART NO.	Q'TY	REMARK
9-1	PLATE KICK RETURN STOPPER	11207-119-000	1	
9-2	FACE ASSY MOVABLE DRIVE	22103-160-000	1	
9-2-1	FACE DRIVE	22102-156-000	1	
9-2-2	BOSS DRIVE FACE	96401-172451	1	1724'51.5
9-2-3	PRIMARY SLIDING SLOT WHEEL	22110-156-000	1	
9-2-4	ROLLER COMP WEIGHT	22121-158-000	6	17 g
9-2-5	PLATE RAMP	22131-158-000	1	f 17
9-2-6	SIDE PIECE	22132-156-000	3	
9-2-7	BUSH	96401-242830	1	24 '28'30
9-2-8	INTERNAL CIRCLIP	94512-2800R	2	RTW-28
9-3	GEAR KICK DRIVE	28211-119-000	1	20T
9-4	STARTER IDLE GEAR ASS'Y	28231-119-000	1	
9-4-1	SPRING STARTER GEAR FRICTION	28223-119-000	1	
9-4-2	GEAR COMP STARTER IDLE	28230-119-000	1	13T/49T
9-4-3	SHAFT STARTER IDLE	28241-119-000	1	
9-4-4	SPRING STARTER IDLE	28242-119-000	1	
9-4-5	SPECIAL PIN	28282-119-000	1	4.5mm
9-4-6	PLAIN WASHER	94101-1225023-C	1	12'25'2.3
9-5	STARTER SPINDLE ASS'Y	28251-119-000	1	
9-5-1	STARTER SPINDLE COMP	28250-119-000	1	
9-5-2	BUSH	96401-121612	1	12'16'12
9-5-3	STARTER SPINDLE BUSH	96401-141816	1	14'18'16
9-5-4	STARTER SPRING	28281-119-000	1	
9-5-5	PLAIN WASHER	94101-1422012-C	1	14'22'1.2
9-5-6	ROLLER	96220-30085	1	3'8.5
9-6	PLAIN WASHER	94101-1225023-C	1	12'25'2.3
9-7	HEX FLANGE NUT	94050-12000-C	1	M12
9-8	HEX FLANGE BOLT	96000-06012-8C	1	M6'12

Aktuelle Preise erfahren sie auf www.motorroller.de

D-10 DRIVEN FACE

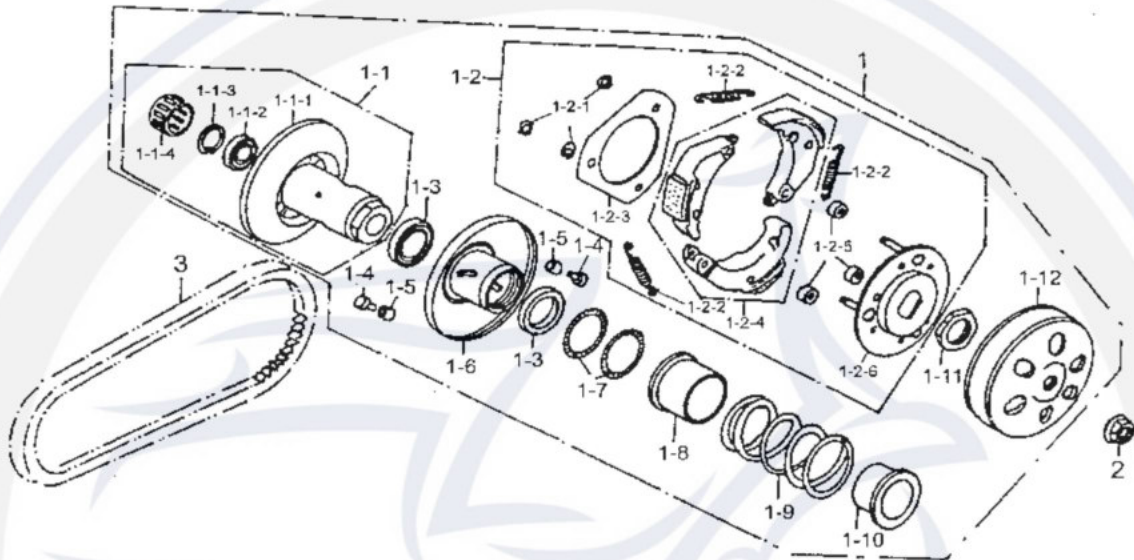

P/N	DESCRIPTION	PART NO.	Q'TY	REMARK
10-1	DRIVE FACE ASS'Y(B)	22000-158-000	1	
10-1-1	SECONDARY FIX SLOT WHEEL	23200-119-000	1	
10-1-1-1	FACE ASS'Y DRIVEN	23210-119-000	1	
10-1-1-2	RADIAL BALL BEARING	96100-6902U	1	6902U
10-1-1-3	INTERNAL CIR CLIP	94512-280IR	1	IRTW-28
10-1-1-4	NEEDLE BEARING	96200-202918	1	20'29'18
10-1-2	PLATE ASS'Y DRIVE	22001-156-000	1	
10-1-2-1	EXTERNAL CIR CLIP	94511-07QDE	3	ETW-7
10-1-2-2	SPRING CLUTCH	22401-119-000	3	
10-1-2-3	PLATE CLUTCH SIDE	22351-119-000	1	
10-1-2-4	CLUTCH WEIGHT SET	22535-156-000	3	
10-1-2-5	RUBBER CLUTCH DAMPER	22804-119-000	3	
10-1-2-6	PLATE COMP DRIVE	22350-119-000	1	
10-1-3	OIL SEAL	96500-34414	2	34'41 '4
10-1-4	GUIDE PIN	23225-119-000	3	
10-1-5	GUIDE	23226-119-000	3	
10-1-6	SECONDARY SLIDING SLOT WHEEL	23220-119-000	1	
10-1-7	OIL RING	91336-119-000	2	36'2
10-1-8	SECONDARY SPRING SEAT	23237-119-000	1	
10-1-9	COMPRESSION SPRING	23233-158-000	1	
10-1-10	COLLER SPRING	23238-119-000	1	
10-1-11	NUT , SPECIAL	90202-119-000	1	M28
10-1-12	CLUTCH COVER COMP	22100-119-000	1	
10-2	HEX FLANGE NUT	94050-12000-C	1	M12
10-3	BELT DRIVE	23100-122-000	1	743'20'30
10-4	TEFLON RING	21326-156-000	1	

D-11 TRANSMISSION

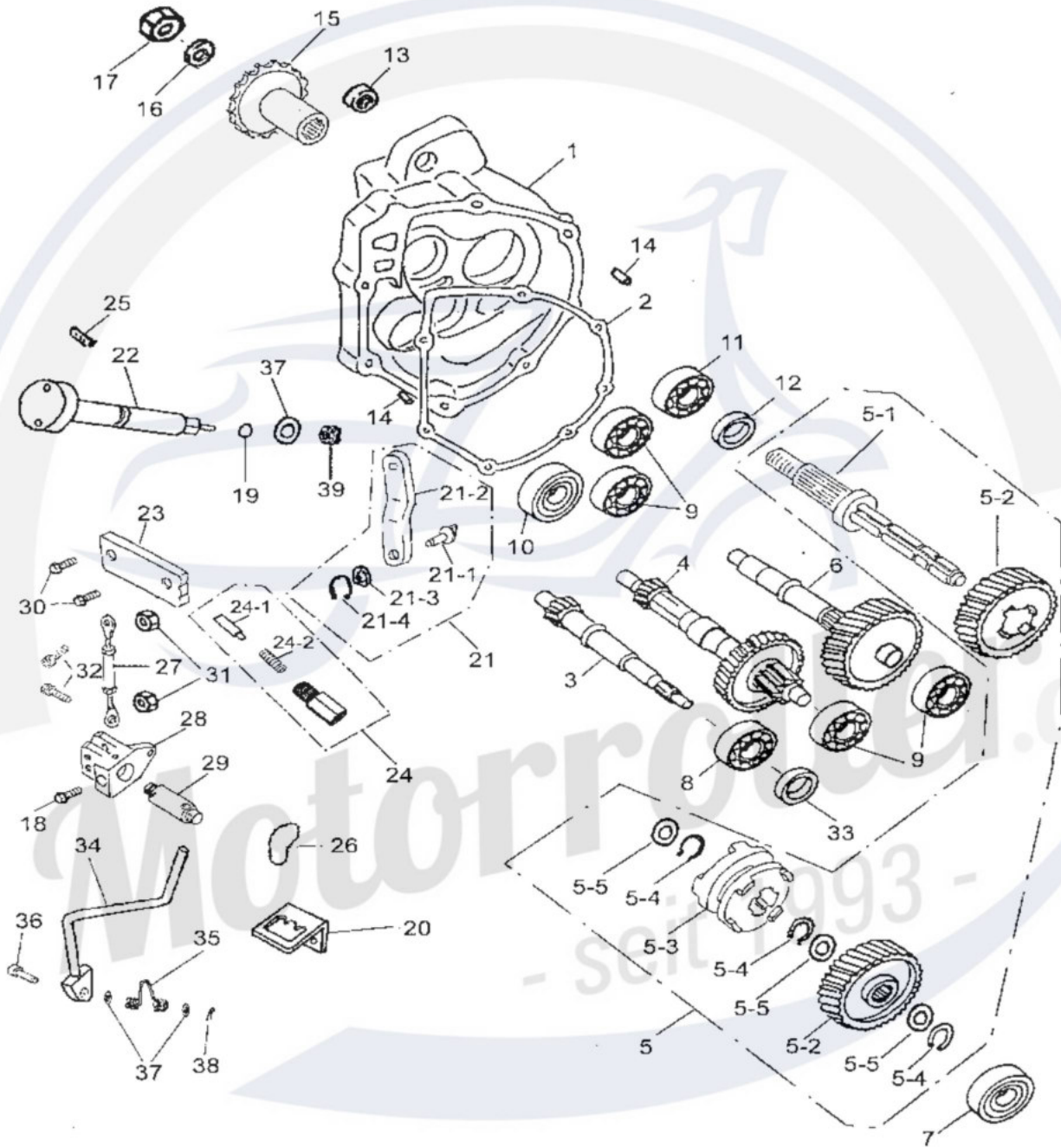

P/N	DESCRIPTION	PART.NO.	Q'TY	REMARK
11-1	MISSION COVER	21301-158-000	1	
11-2	MISSION COVER GASKET	21395-156-000	1	
11-3	SHAFT , DRIVE	23411-119-000	>1	
11-4	MAIN AXLE COMP	23420-156-000	1	
11-5	SHAFT , FINAL ASS.Y	23440-156-000	1	
11-5-1	SHAFT , FINAL	23431-156-000	1	
11-5-2	GEAR , TRANSMISSION	23434-156-000	2	
11-5-3	CLUTCH	28430-156-000	1	
11-5-4	C- CIRCLIP	23436-156-000	3	
11-5-5	SPECIAL WASHER	23435-156-000	3	

Aktuelle Preise erfahren sie auf www.motorroller.de

11-6	COUNTER SHAFT ASS'Y	23433-156-000	1	
11-7	BEARING	96100-62030	1	CS05 6203
11-8	BEARING	96100-62040	1	C3 6204
11-9	BEARING	96100-62020	4	CS05 6202
11-10	BEARING	96100-TMB301	1	TMB301
11-11	BEARING	96100-6004U	1	6004LU
11-12	OIL SEAL	96500-27427	1	
11-13	RUBBER BUSH	96400-082223	1	8x22x23
11-14	DOWEL PIN	94301-08140	2	8x14
11-15	DRIVE SPROCKET	23801-159-000	1	17T
11-16	PLAIN WASHER	94101-1629030-C	1	16x29x3
11-17	NYLON INSERT LOCK NUT	90350-16000-C	1	M16
11-18	HEX FLANGE BOLT	96000-06025-K	1	M6x25
11-19	O-RING	91312-111-000	1	
11-20	FIX CATCH SUPPORT	21323-156-000	1	
11-21	TRANSMISSION FORK ASS.Y	21310-156-000	1	
11-21-1	TRANSMISSION FORK	21311-156-000	1	
11-21-2	TRANSMISSION SHAFT	21312-156-000	1	
11-21-3	SPECLAL WASHER	23437-156-000	1	
11-21-4	C - CINCLIP	23438-156-000	1	
11-22	TRANSMISSION LINK	21313-156-000	1	
11-23	TRANSMISSION POSITION FIX PLATE	21314-156-000	1	
11-24	TRANSMISSION POSITION FIX BUTTON	21315-156-000	1	
11-24-1	TRANSMISSION FIX PIN	21324-156-000	1	
11-24-2	TRANSMISSION FIX SPRING	21325-156-000	1	
11-25	HEX SOCKET FIX BOLT	91001-05008-K	1	M5x8
11-26	TRANSMISSION LEVER ROD	21322-156-000	1	
11-27	TRANSMISSION FORK LINK	21316-156-000	1	
11-28	TRANSMISSION SET	21317-156-000	1	
11-29	TRANSMISSION SET FIX LINK ASS,Y	21318-156-000	1	
11-30	HEX FLANGE BOLT	96000-06012-C	2	M6x12
11-31	NYLON INSERT LOCK NUT	90350-06000-K	2	M6
11-32	HEX SOCKET BOLT	91000-06025-K	2	M6x25
11-33	OIL SEAL	96500-20326	1	20x32x6
11-34	TRANSMISSION LEVER	21319-156-000	1	
11-35	TRANSMISSION LEVER SPRING	21320-156-000	1	
11-36	TRANSMISSION LEVER FIX PIN	21321-156-000	1	
11-37	PLAIN WASHER	94101-0816015-C	3	8x16x1.5
11-38	COTTER PIN	94201-24190	1	
11-39	HEX NUT WITH SERRATION	90350-08000-UK	1	

D-12 CRANKCASE DOC

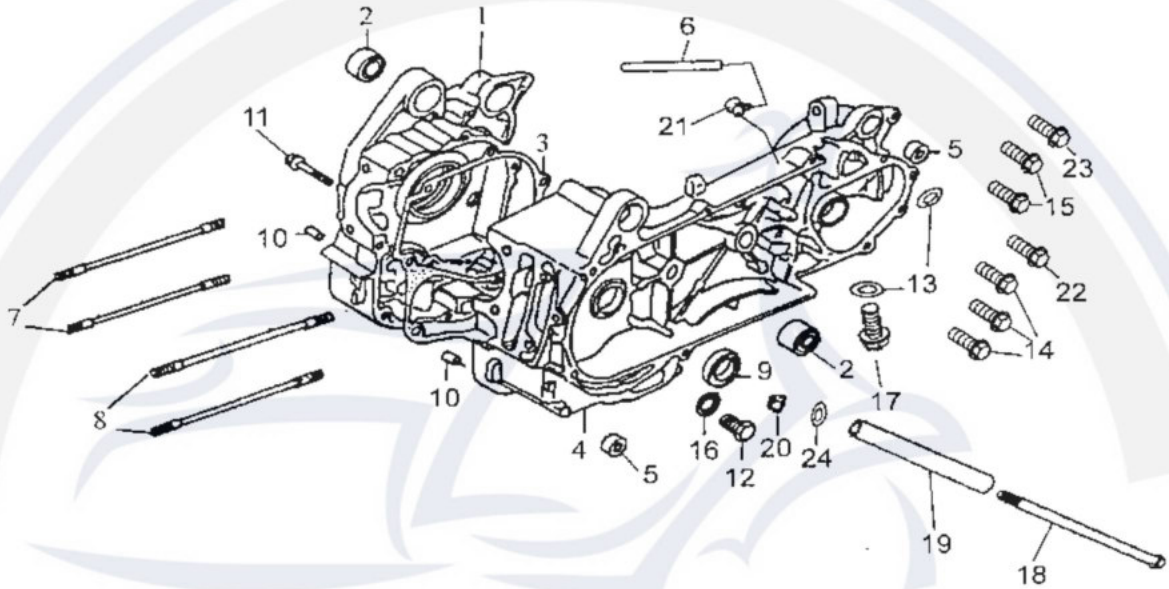

P/N	DESCRIPTION	PART NO.	Q'TY	REMARK
12-1	RIGHT CRANKCASE	11101-158-000	1	
12-2	BUSH ENGINE HANGER RUBBER	96400-102820	2	10'28'20
12-3	GASKET CRANKCASE	11191-122-000	1	
12-4	LEFT CRANKCASE	11201-158-000	1	
12-5	RUBBER BUSHING	96400-082223	2	8'22'23
12-6	TUBE BREATHER	16615-113-000	1	
12-7	STUD BOLT	91001-08181-C	2	M8'181
12-8	STUD BOLT	91001-08187-C	2	M8'187
12-9	OIL SEAL	96500-19305	1	19.8'30X5
12-10	DOWEL PIN	94301-08140	2	8'14
12-11	HEX FLANGE BOLT	96000-06050-C	1	M6'50
12-12	HEX FLANGE BOLT	96000-12015-14C	1	M12'15
12-13	PLAIN WASHER (ALUMINUM)	94101-0816020	2	8x16x2
12-14	HEX FLANGE BOLT	96000-06060-08-C	3	M6x60
12-15	HEX FLANGE BOLT	96000-06065-08-C	3	M6x65
12-16	PLAIN WASHER	94101-1221320-L	1	12'21.3'2
12-17	HEX FLANGE BOLT	96000-08012-10C	2	M8x12
12-18	HEX FLANGE BOLT	96000-10197-C	1	M10x197
12-19	ENGINE SPACER COLLAR	11150-156-000	1	10*17*125
12-20	NYLON INSERT LOCK NUT	90350-10000-C	1	M10
12-21	BREATHER JOINT	16610-113-000	1	
12-22	HEX FLANGE BOLT	96000-06045-08-C	1	M6x45
12-23	HEX FLANGE BOLT	96000-06070-08-C	1	M6*70
12-24	PLAIN WASHER	94101-1022020-C	1	10*22*2

D-13 CRANK SHAFT/PISTON

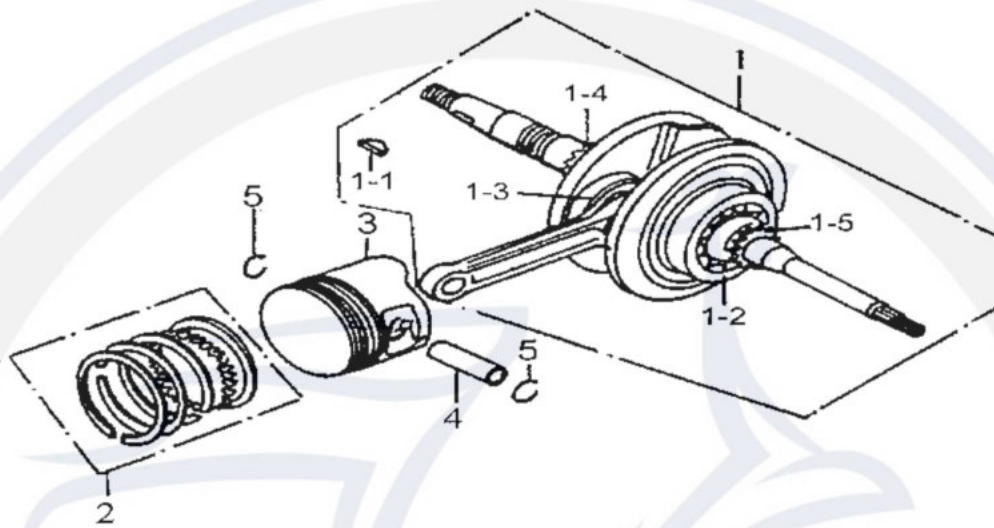

P/N	DESCRIPTION	PART NO.	Q'TY	REMARK
13-1	CRANKSHAFT ASSY	13000-156-001	1	
13-1-1	SEMICYCLE KEY	90471-119-000	1	25'4'14
13-1-2	BEARING	CSSC04A86CS12	1	56'22'15
13-1-3	NEDDLE BEARING	96200-283313	1	
13-1-4	TIMING GEAR	14311-119-000	1	17T
13-1-5	CAM TRANSMISSION GEAR	14322-158-000	1	
13-1-6	BEARING	TMB305V32	1	62'25'17
13-2	PISTION RING SET	13011-158-000	1	
13-3	PISTON	13100-158-000	1	
13-4	PISTON PIN	13111-158-000	1	10x15x42
13-5	CUP PISTON PIN	13115-119-000	2	

D-14 AIR CLEANER

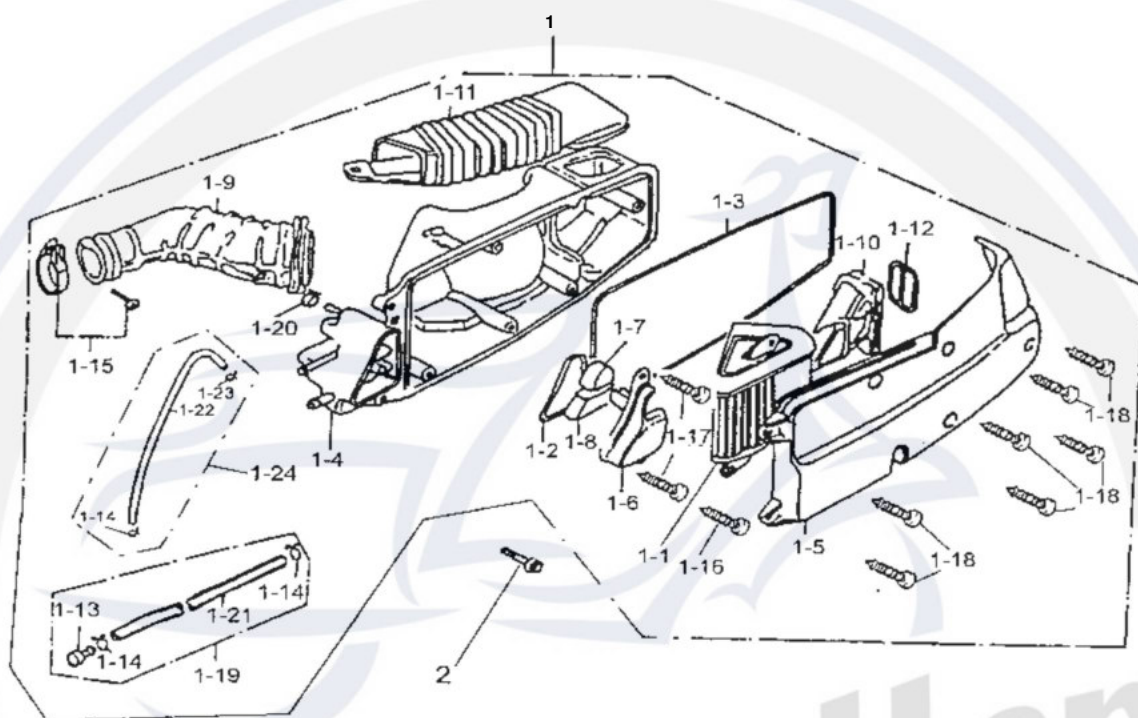

P/N	DESCRIPTION	PART NO.	Q'TY	REMARK
14-1	AIR CLEANER ASSY	17200-156-000	1	
14-1-1	AIR CLEANER ELEMENT	17205-119-000	1	
14-1-2	SEAL OIL CATCH	17212-119-000	1	
14-1-3	SEAL OIL CLEANER COVER	17213-119-000	1	
14-1-4	AIR CLEANER CASE	17206-119-000	1	
14-1-5	CLEANER CASE CAP	17207-119-000	1	
14-1-6	COVER OIL CATCH	17232-119-000	1	
14-1-7	FILTER BREATHER	17234-119-000	1	
14-1-8	FILTER OIL CATCH	17235-119-000	1	
14-1-9	AIR CLEANER JOINT	17253-119-000	1	
14-1-10	DUCT AIR CLEANER IN	17255-119-000	1	
14-1-11	DUCT AIR CLEANER CASE	17257-119-000	1	
14-1-12	SPRING IN DUCT	17258-119-000	1	
14-1-13	PLUG BREATHER TUBE	17370-119-000	1	
14-1-14	CLIP	94510-12000	3	12mm
14-1-15	INTAKE MANIFOLD HOSE CLAMP	14110-119-000	1	
14-1-16	PAN PHILLIPS BOLT	93500-05010-K	2	M5'10
14-1-17	TAPPING SCREW TRUSS HEAD PHILLIPS	93903-04012-K	2	4'12
14-1-18	TAPPING SCREW TRUSS HEAD PHILLIPS	93903-05020-K	7	5'20
14-1-19	TUBE ASS'Y DRAIN	17360-119-000	1	
14-1-20	CLAMP TUBE	94509-09000	1	
14-1-21	TUBE VINYL	94400-08012	1	8'12'240
14-1-22	BREATHER TUBE	11211-119-000	1	6'8.5
14-1-23	CLIP	94510-08000	1	8'0.8
14-1-24	BREATHER TUBE ASS'Y	11210-119-000	1	
14-2	HEX FLANGE BOLT	96000-06032-814-C	2	M6'32

D-15 EXHANST MUFFLER,CARBURETOR 000,000

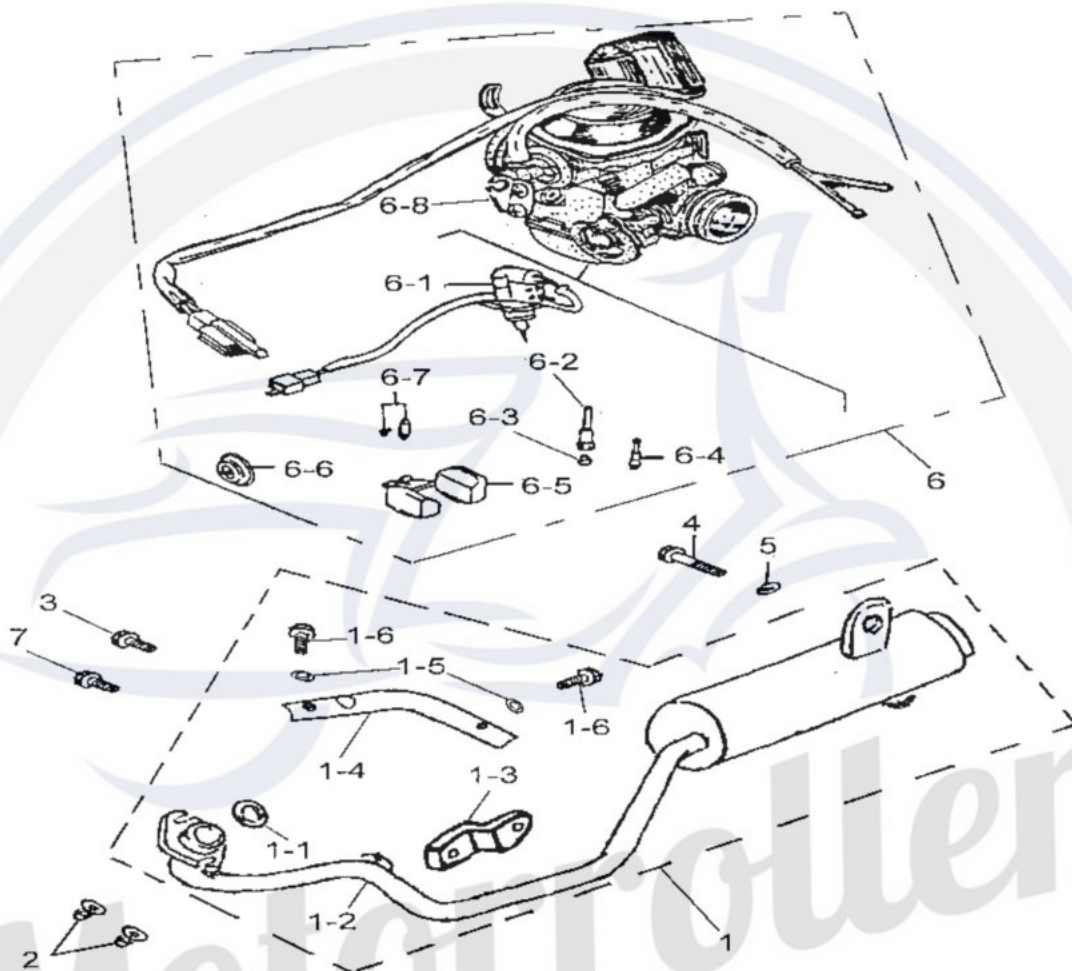

P/N	DESCRIPTION	PART NO.	Q'TY	REMARK
15-1	EXHAUST PIPE ASSY	18300-156-001	1	
15-1-1	EXHAUST PIPE GASKET	18291-119-000	1	25.4*34*4
15-1-2	EXHAUST PIPE	18301-156-001	1	
15-1-3	EXHAUST PIPE FIX PLATE	18317-156-000	1	
15-1-4	EXHAUST PIPE PROTECTOR	18315-156-001	1	
15-1-5	GASKET	94102-0613010	2	6*13*1
15-1-6	HEX FLANGE BOLT	93500-060010	2	M6*10
15-2	NUT CAP	90301-08000-C	2	M8
15-3	HEX FLANGE BOLT	96000-08016-K	1	M8x16
15-4	HEX FLANGE BOLT	96000-08030-K	1	M8x30
15-5	PLAIN WASHER	94101-1022020-C	1	10*22*2
15-6	CARBURETOR ASSY	16100-156-00A	1	16100-119-000
15-6-1	PLUNGER STARTER	17215-119-000	1	
15-6-2	NEEDLE NOZZLE	16105-119-000	-1	
15-6-3	MAIN NOZZLE	16108-119-000	1	#112
15-6-4	PILOT JET	16110-119-000	1	#35
15-6-5	FLOAT	16118-119-000	1	
15-6-6	PLUNGER FILM	16048-119-000	1	
15-6-7	PLUNGER FILM	16117-119-000	1	
15-6-8	THROTTLE CABLE FIX SEAT	16120-156-000	1	
15-7	HEX FLANGE BOLT	96000-08025-K	1	M8x25

Aktuelle Preise erfahren sie auf www.motorroller.de

D-16 FRAME BODY

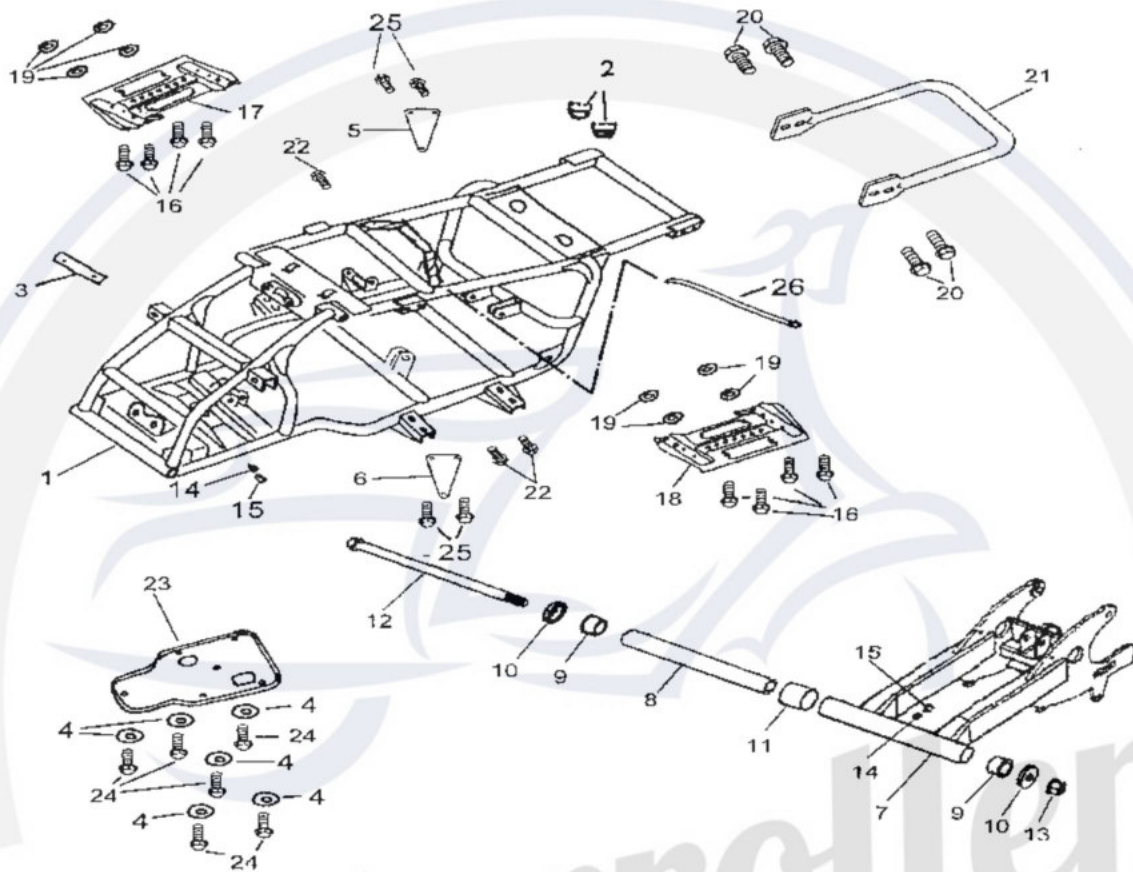

P/N	DESCRIPTION	PART NO.	Q'TY	REMARK
16-1	FRAME COMP	50100-162-001	1	
16-2	SEAT RUBBER	77220-131-000	2	7E37x/E13x23
16-3	FLANGE NUMBER PLATE	50130-131-000	1	
16-4	SPRING WASHER	94111-07500-K	6	f7.5
16-5	RIGHT ENGING BRACKET PLATE	50351-158-000	1	
16-6	LEFT ENGING BRACKET PLATE	50355-158-000	1	
16-7	SWING ARM SUB ASSY	52410-156-001	1	
16-8	SWING ARM SPACER TUBE	52420-131-000	1	
16-9	GREASE CONTAIN SEAT	52421-131-000	2	
16-10	SWING ARM SEAT COVER	52422-131-000	2	
16-11	RUBBER SLEEVE	52423-156-000	1	
16-12	HEX FLANGE BOLT	96000-14290-C	1	M14x290
16-13	INSERT LOCK NUT	90350-14000-UC	1	M14
16-14	GREASE VALVE	51300-131-000	2	
16-15	GREASE VALVE RUBBER CAP	51301-131-000	2	
16-16	HEX FLANGE BOLT	96000-08012-K	8	M8x12
16-17	RIGHT FOOTWELL BOTTOM BOARD	51105-156-000	1	
16-18	LEFT FOOTWELL BOTTOM BOARD	51120-156-000	1	
16-19	FOOT REST GROMMER	64320-151-000	1 8	
16-20	HEX FLANGE BOLT	96000-08014-K	4	M8x14
16-21	REAR HANDLE	50105-159-000	1	
16-22	HEX FLANGE BOLT	96000-08040-K	3	M8x40
16-23	PROTECTION FRAME BOTTOM BOARD	50106-156-000	1	
16-24	HEX WASHER FACE BOLT	96000-06008-K	6	M6x8
16-25	HEX FLANGE BOLT	96000-08035-K	4	M8x35
16-26	STRAP	90569-131-000	1	

Aktuelle Preise erfahren sie auf www.motorroller.de

D-17 BUMPER

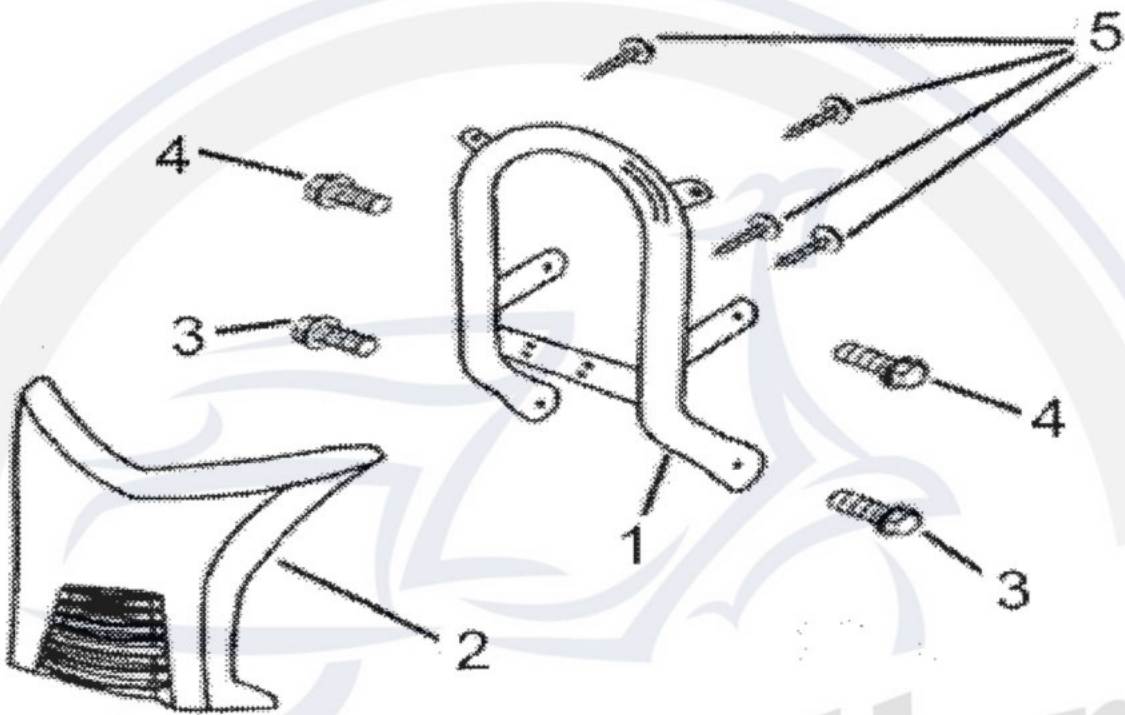

P/N	DESCRIPTION	PART NO.	Q'TY	REMARK
17-1	BUMPER	50450-157-001	1	
17-2	BUMPER COVER	50460-157-000	1	
17-3	HEX FLANGE BOLT	96000-08016-K	2	M8x16
17-4	HEX FLANGE BOLT	96000-08014-K	2	M5x12
17-5	TAPPING SCREW	93903-05012-K	4	M5x12

D-18 SWING ARM, FOOTREST □□□,□□□

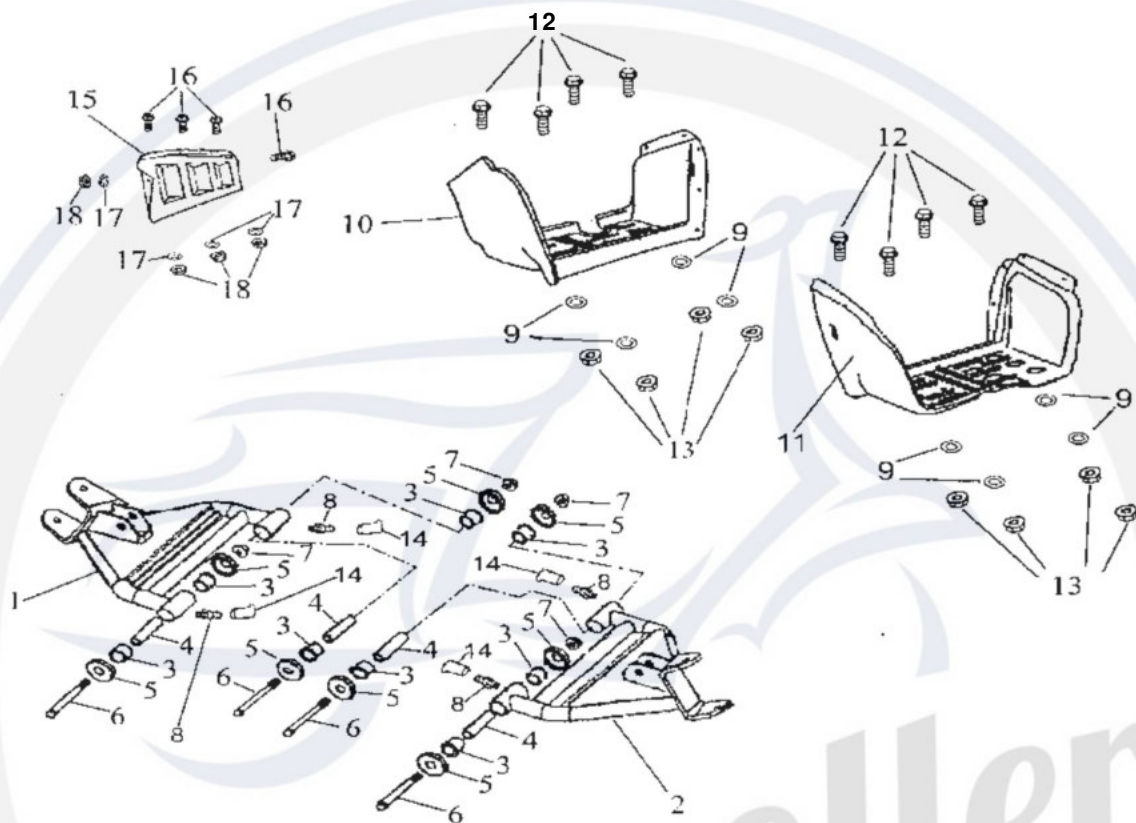

P/N	DESCRIPTION	PART NO.	Q'TY	REMARK
18-1	RIGHT SUSPENSION ARM	53030-156-001	1	
18-2	SUSPENSION ARM	53130-156-001	1	
18-3	SUSPENSION ARM BUSH	53135-156-000	8	15.5*21*18
18-4	SPACER TUBE	53140-156-000	4	10*15*55
18-5	DUST PROOF RUBBER	52426-156-000	8	
18-6	HEX FLANGE BOLT	96000-10075-KL	4	M10x75
18-7	HEX FLANGE NUT	94050-10000-C	4	M10
18-8	GREASE VALVE	51300-131-000	4	
18-9	PLAIN WASHER	94101-0613010-K	8	6x13x1
18-10	RIGHT FOOTREST	64300-156-002	1	»
18-11	LEFT FOOTREST	64310-156-001	1	
18-12	HEX BOLT WITH WASHER	92000-06016-K	8	M6x16
18-13	NYLON INSERT LOCK NUT	90350-06000-K	8	M6
18-14	GREASE VALVE RUBBER CAP	51301-131-000	4	
18-15	HEAT SHIELD	50480-156-000	• 1	
18-16	PAN PHILLIPS BOLT	93100-05016-K	4	M5*16
18-17	PLAIN WASHER	94101-0514010-K	4	5*14*1
18-18	NYLON INSERT LOCK NUT	90350-05000-K	4	M5

D-19 FENDER

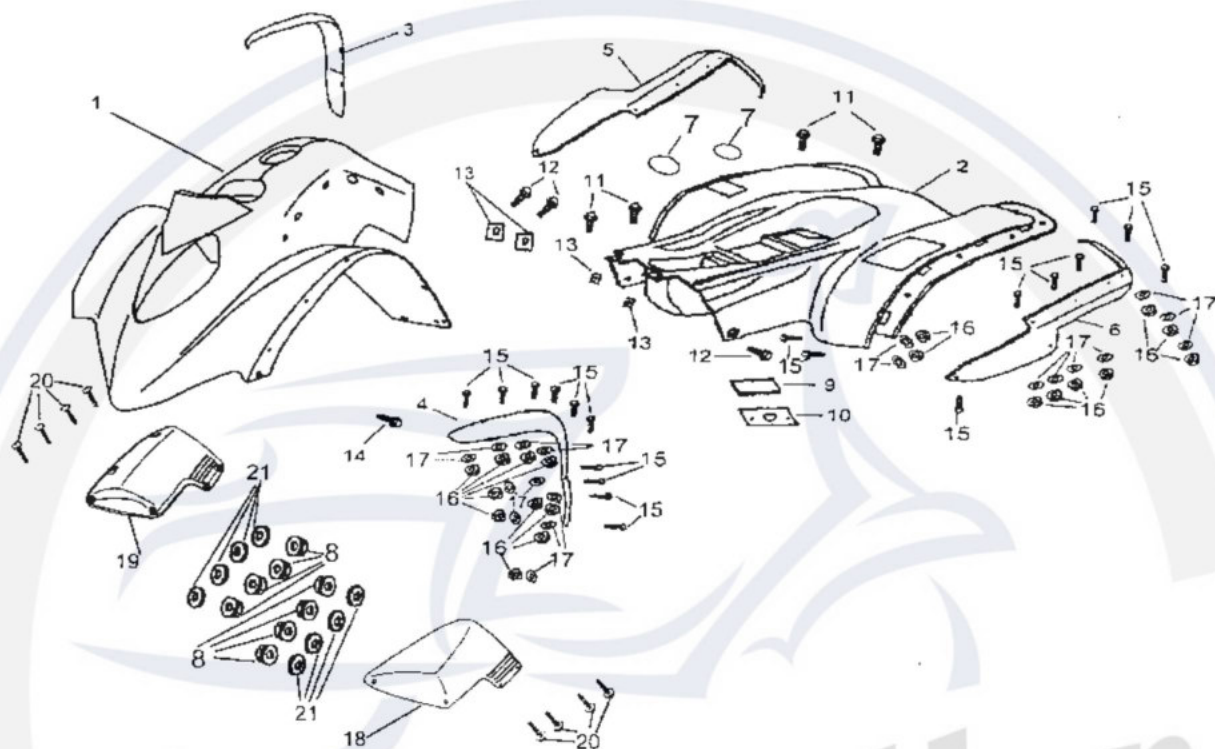

P/N	DESCRIPTION	PART.NO.	Q'TY	REMARK
19-1	FRONT FENDER (RED)	61100-162-R507	1	Red
19-1	FRONT FENDER (GREEN)	61100-162-G502	1	Green
19-2	REAR FENDER (RED)	61000-156-R507	1	Red
19-2	REAR FENDER (GREEN)	61000-156-G502	1	Green
19-3	FRONT RH. MUDFLAP	61105-157-000	1	
19-4	FRONT LH. MUDFLAP	61110-157-000	1	
19-5	REAR RH. MUDFLAP	61005-159-000	1	61005-156-000
19-6	REAR LH. MUDFLAP	61011-159-000	1	61010-156-000
19-7	O-RING	91313-156-000	2	60.5*2.4
19-8	NYLON INSERT LOCK NUT	90350-04000-K	8	M4
19-9	BATTERY RUBBER	31510-131-000	1	
19-10	PROTECTOR PAD	80140-131-000	1	
19-11	HEX BOLT WITH PLAIN WASHER	92000-06016-K	4	M6*16
19-12	PAN PHILLIPS BOLT WITH PLAIN WASHER	96318-06016-K	4	M6*16
19-13	U PLATE NUT	90344-06000-C	4	M6
19-14	HEX BOLT WITH FIX WASHER	92003-06016-K	2	i
19-15	PAN PHILLIPS BOLT	93100-05012-K	48	M5 *12
19-16	NYLON INSERT LOCK NUT	90350-05000-K	48	M5
19-17	PLAIN WASHER	94101-0514010-K	48	5*14*1mm
19-18	LEFT DECORATE COVER	17660-157-000	1	
19-19	RIGHT DECORATE COVER	17650-157-000	• 1	
19-20	PAN PHILLIPS BOLT	93100-04016-K	8	M4x16
19-21	PLAIN WASHER	94101-0412010-K	8	4*12*1

D-20 SEAT

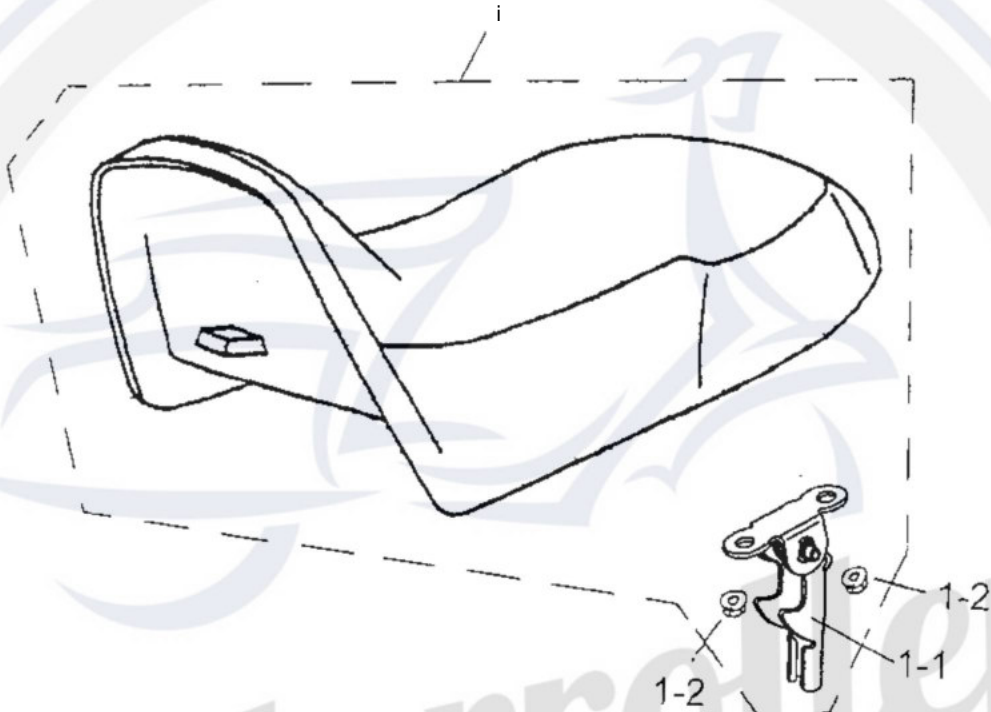

P/N	DESCRIPTION	PART.NO.	Q'TY	REMARK
20-1	SEAT ASS'Y (SILVER / BLACK)	77200-162-00A	1	Red ATV
20-1	SEAT ASS'Y (BLACK / GRAY)	77200-157-003	1	Green ATV
20-1-1	SEAT FIX HOOK	77210-131-000	1	
20-1-2	HEX FLANGE NUT	94Q50-06ÜÜ-C	2	M6

D-21 FUEL TANK

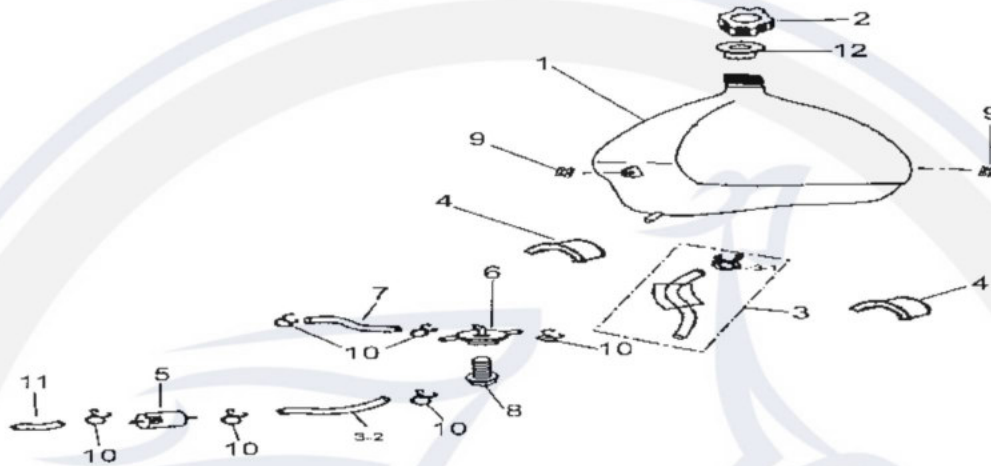

P/N	DESCRIPTION	PART.NO.	Q"TY	REMARK
21-1	FUEL TANK COMP	17500-156-000	1	
21-2	FUEL TANK CAP	17620-156-000	1	
21-2-1	BREATHER SHEET	17621-156-000	1	
21-3	FUEL TUBE A	94401-05009-1	1	210mmx05..06.5
21-3-1	CLIP	94510-12000	1	
21-3-2	FUEL TUBE B	94400-05009-100	1	L= 100mm
21-4	FUEL TANK RUBBER MAT	64319-131-000	2	
21-5	FUEL FILTER ASSY	16952-111-000	1	
21-6	COCK ASSPY,FUEL AUTO	16950-111-000	1	
21-7	SIDE OIL TUBE	94400-04008-165	1	L= 165mm
21-8	HEX FLANGE BOLT	96000-06016-K	1	M6x16
21-9	GROMMER	83574-131-000	2	
21-10	CLIP	94510-08000	6	
21-11	FUEL TUBE C	94401-04008	1	80mm04..05
21-12	BREATHER FILM	17625-131-001	1	

D-22 SUSPENSION

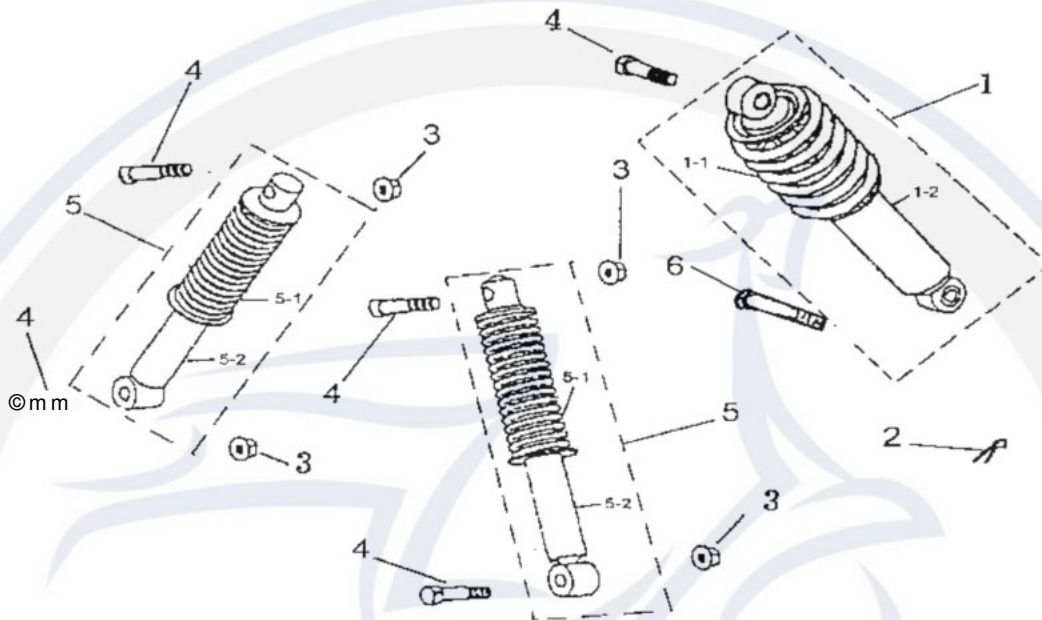

P/N	DESCRIPTION	PART.NO.	Q'TY	REMARK
22-1	REAR SUSPENSION	52400-156-001	1	Black
22-1-1	REAR SUSPENSION SPRING	52401-156-001	1	Black
22-1-2	REAR SUSPENSION INNER TUBE COMP	52402-156-000	1	
22-2	COTTER PIN	94201-24190	1	
22-3	HEX FLANGE NUT	94050-10000-C	4	M10
22-4	HEX FLANGE NUT	96000-10040-KL	5	M10'40(.)
22-5	FRONT SUSPENSION	51100-156-001	2	Black
22-5-1	FRONT SUSPENSION SPRING	51101-156-000	2	Black
22-5-2	FRONT SUSPENSION INNER TUBE COMP	51102-156-000	2	
22-6	REAR SUSPENSION FIX AXLE	52415-156-000	1	012x70

D-25 FRONT BRAKE DISK SYSTEM nnnri

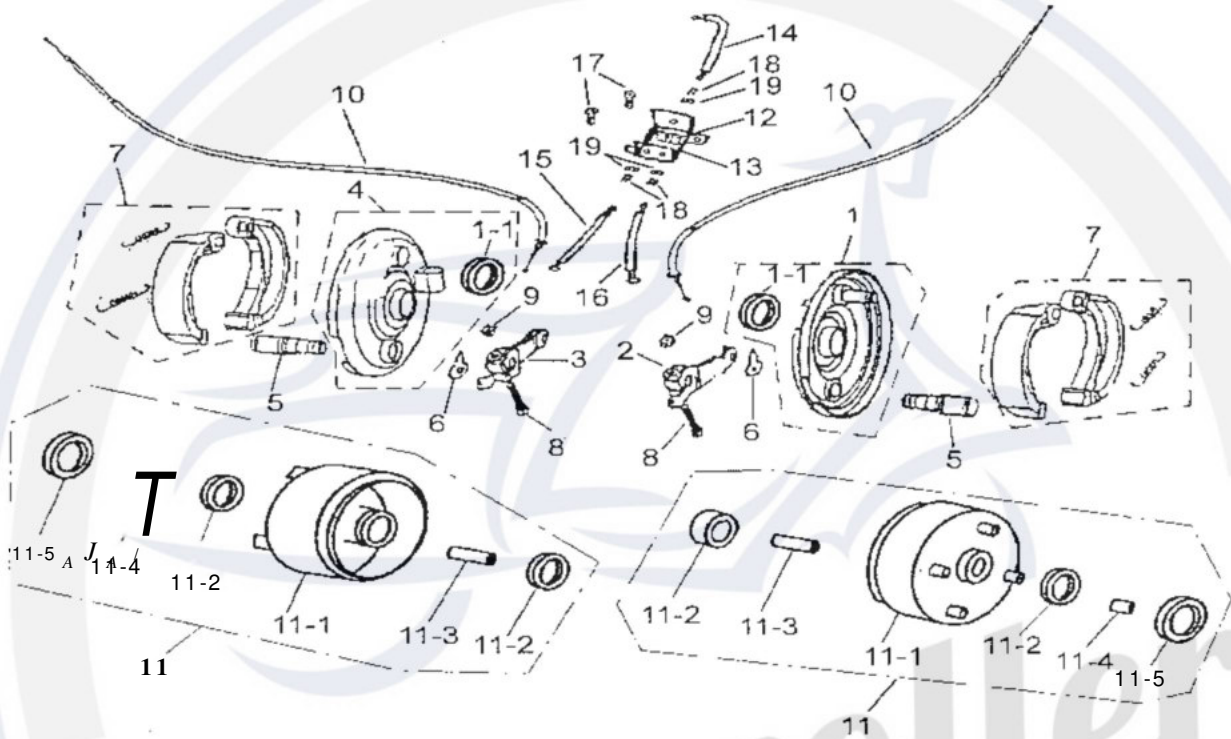

PiN	DESCRIPTION	PART NO.	Q'TY	REMARK
25-1	FRONT BRAKE PLATE (L)	45010-156-001	1	
25-1-1	OIL SEAL	96500-4052060	2	
25-2	FRONT BRAKE ARM (L)	45410-159-000	1	
25-3	FRONT BRAKE ARM (R)	45409-159-000	1	
25-4	FRONT BRAKE PLATE (R)	45020-156-001	1	
25-5	FRONT BRAKE CAM SHAFT	45141-156-000	2	
25-6	BRAKE GUIDE	45142-156-000	2	
25-7	BRAKE SHOE COMP	43120-111-OOC	2	
25-8	HEX BOLT	96000-06032-C	2	M6x32
25-9	HEX NUT	94001-06000-C	2	M6
25-10	FRONT BRAKE CABLE	45450-156-001	2	
25-11	FRONT BRAKE DRUM ASS'Y	45005-156-000	2	
25-11-1	FRONT BRAKE DRUM	45008-156-000	2	«
25-11-2	BEARING	96100-6003LU	2	6003LU
25-11-3	INSIDE SPACER COLLAR	44311-156-000	2	
25-11-4	OUTSIDE SPACER COLLAR	44312-156-000	2	
25-11-5	OIL SEAL	96500-2335060	2	23x35x6
25-12	CONNECTER WIRE LEVELR	45452-133-000	1	
25-13	CONNECTER WIRE SEAT	45453-133-000	1	
25-14	FRONT PEDAL BRAKE CONNECTED CABLE	45454-159-000	1	
25-15	R.FRONT PEDAL BRAKE CABLE	45455-159-000	1	
25-16	L.FRONT PEDAL BRAKE CABLE	45457-159-000	1	
25-17	FLAT HEAD PHILLIPS BOLT	93902-06008-B	2	M6X8
25-18	INSERT BOLT	45421-133-000	3	
25-19	INSERT NUT	45422-133-000	3	

D-23 FRONT WHEEL

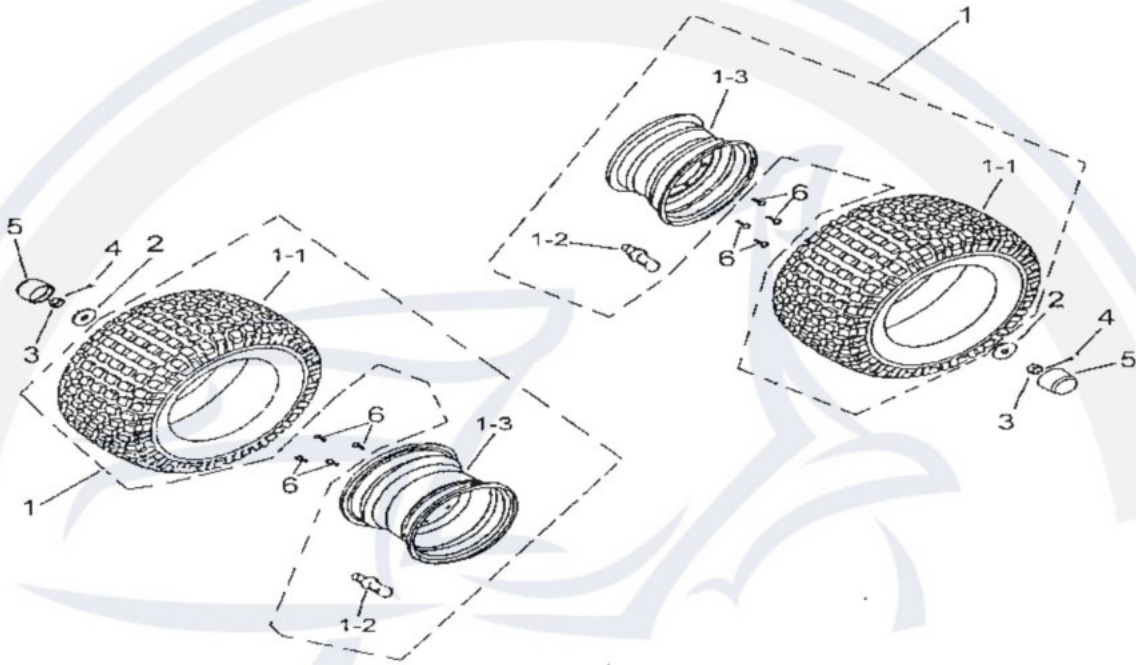

P/N	DESCRIPTION	PART.NO.	QTY	REMARK
23-1	FRONT WHEEL ASSY	42700-156-00R	2	21x7-10
23-1-1	TIRE	42711-156-000	2	21x7-10
23-1-2	RIM VALVE	42616-131-000	2	
23-1-3	WHEEL	42701-156-000	2	10"x5.5
23-2	PLAIN WASHER	94102-1440045-C	2	14x40x4.5
23-3	INSERT LOCKNUT	90352-14000-C	2	M14
23-4	COTTER PIN	94201-32320	2	3.2x32
23-5	RUBBER CAP	42730-151-000	2	
23-6	NYLON INSERT LOCK NUT	90350-10000-UC	8	M10

D-22 SUSPENSION []

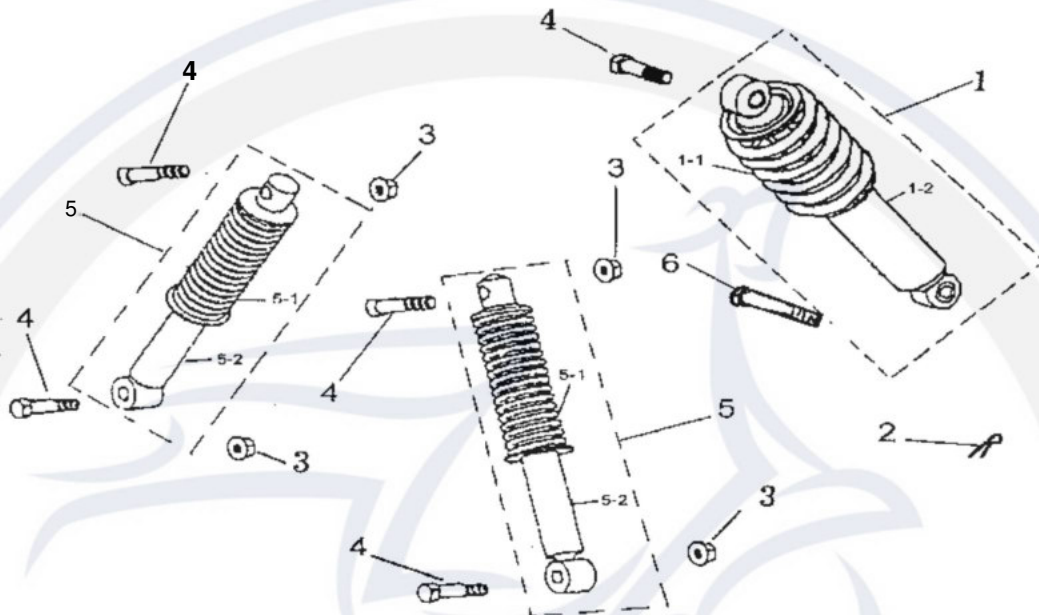

P/N	DESCRIPTION	PART.NO.	Q'TY	REMARK
22-1	REAR SUSPENSION	52400-156-001	1	Black
22-1-1	REAR SUSPENSION SPRING	52401-156-001	1	Black
22-1-2	REAR SUSPENSION INNER TUBE COMP	52402-156-000	1	
22-2	COTTER PIN	94201-24190	1	
22-3	HEX FLANGE NUT	94050-10000-C	4	M10
22-4	HEX FLANGE NUT	96000-10040-KL	5	M10'40(.)
22-5	FRONT SUSPENSION	51100-156-001	2	Black
22-5-1	FRONT SUSPENSION SPRING	51101-156-000	2	Black
22-5-2	FRONT SUSPENSION INNER TUBE COMP	51102-156-000	2	
22-6	REAR SUSPENSION FIX AXLE	52415-156-000	1	012x70

D-24 REAR WHEEL

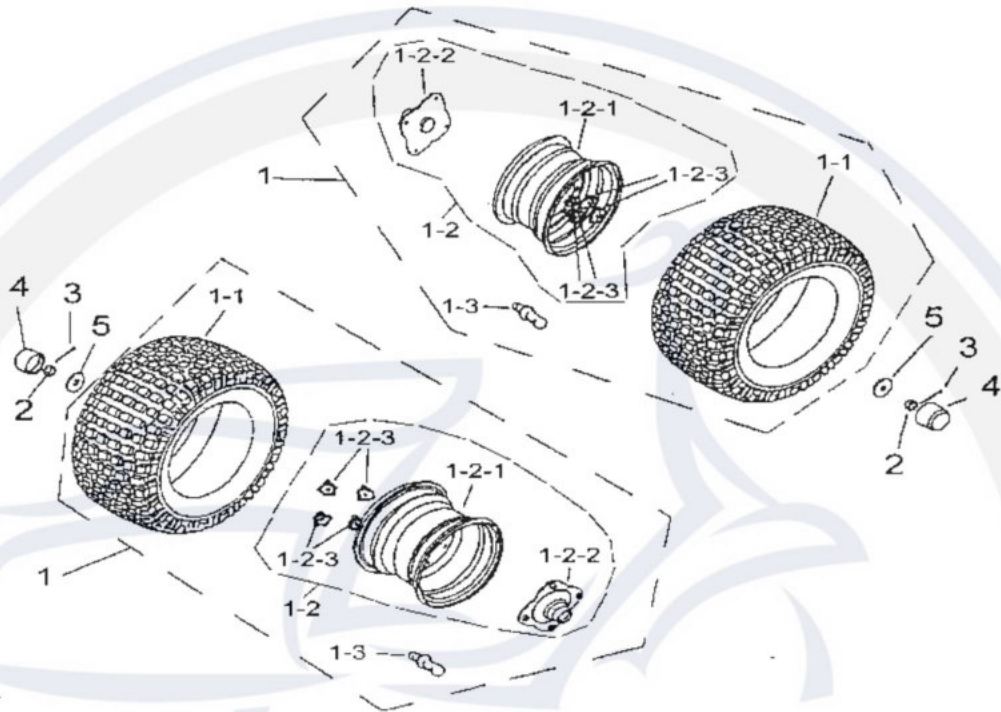

P/N	DESCRIPTION	PART,NO.	Q"TY	REMARK
24-1	REAR WHEEL ASSY	42800-156-OOS	2	21x10-8
24-1-1	TIRE	42811-156-000	2	21x10-8
24-1-2	REAR RIM ASS'Y	42706-156-000	1	
24-1-2-1	WHEEL	42801-156-000	2	8"x8
24-1-2-2	SHAFT CONNECTER	97010-156-001	2	
24-1-2-3	NYLON INSERT LOCK NUT	90350-10000-UC	8	M10
24-1-3	RIM VALVE	42616-131-000	2	
24-2	INSERT LOCK NUT	90352-14000-C	2	M14
24-3	COTTER PIN	94201-32320	2	3.2x320
24-4	RUBBER CAP	42730-151-000	2	
24-5	PLAIN WASHER	94101-1440045-C	2	14x40x4.5

D-25 FRONT BRAKE DISK SYSTEM

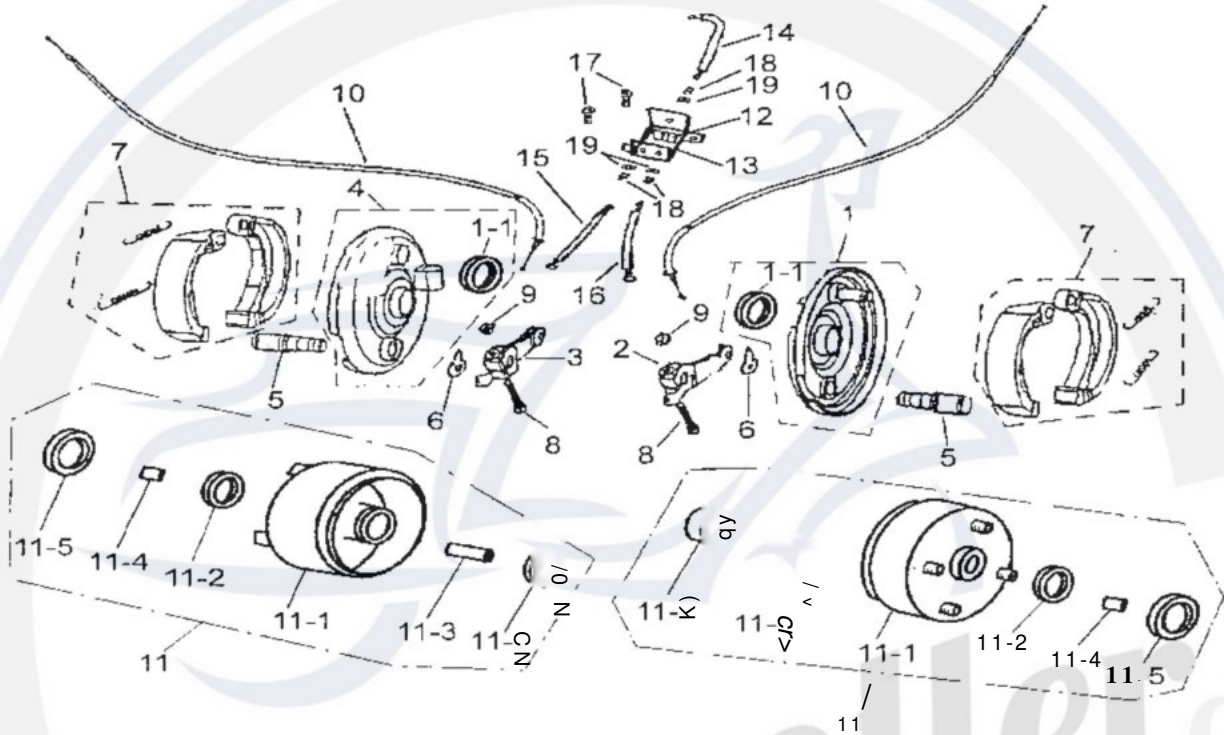

P/N	DESCRIPTION	PART,NO.	q"TY	REMARK
25-1	FRONT BRAKE PLATE (L)	45010-156-001	1	
25-1-1	OIL SEAL	96500-4052050	2	
25-2	FRONT BRAKE ARM (L)	45410-159-000	1	
25-3	FRONT BRAKE ARM (R)	45409-159-000	1	
25-4	FRONT BRAKE PLATE (R)	45020-156-001	1	
25-5	FRONT BRAKE CAM SHAFT	45141-156-000	2	
25-6	BRAKE GUIDE	45142-156-000	2	
25-7	BRAKE SHOE COMP	43120-111-00C	2	
25-8	HEX BOLT	96000-06032-C	2	M6x32
25-9	HEX NUT	94001-06000-C	2	M6
25* 10	FRONT BRAKE CABLE	45450-156-001	2	
25-11	FRONT BRAKE DRUM ASS'Y	45005-156-000	2	
25-11-1	FRONT BRAKE DRUM	45008-156-000	2	«
25-11-2	BEARING	96100-6003LU	2	6003LU
25-11-3	INSIDE SPACER COLLAR	44311-156-000	2	
25-11-4	OUTSIDE SPACER COLLAR	44312-156-000	2	
25-11-5	OIL SEAL	96500-2335060	2	23x35x6
25-12	CONNECTER WIRE LEVELR	45452-133-000	1	
25-13	CONNECTER WIRE SEAT	45453-133-000	1	
25-14	FRONT PEDAL BRAKE CONNECTED CABLE	45454-159-000	1	
25-15	R.FRONT PEDAL BRAKE CABLE	45455-159-000	1	
25-16	L.FRONT PEDAL BRAKE CABLE	45457-159-000	1	
25-17	FLAT HEAD PHILLIPS BOLT	93902-06008-B	2	M6X8
25-18	INSERT BOLT	45421-133-000	3	
25-19	INSERT NUT	45422-133-000	3	

Aktuelle Preise erfahren sie auf www.motorroller.de

D-26 REAR BRAKE SYSTEM finni I

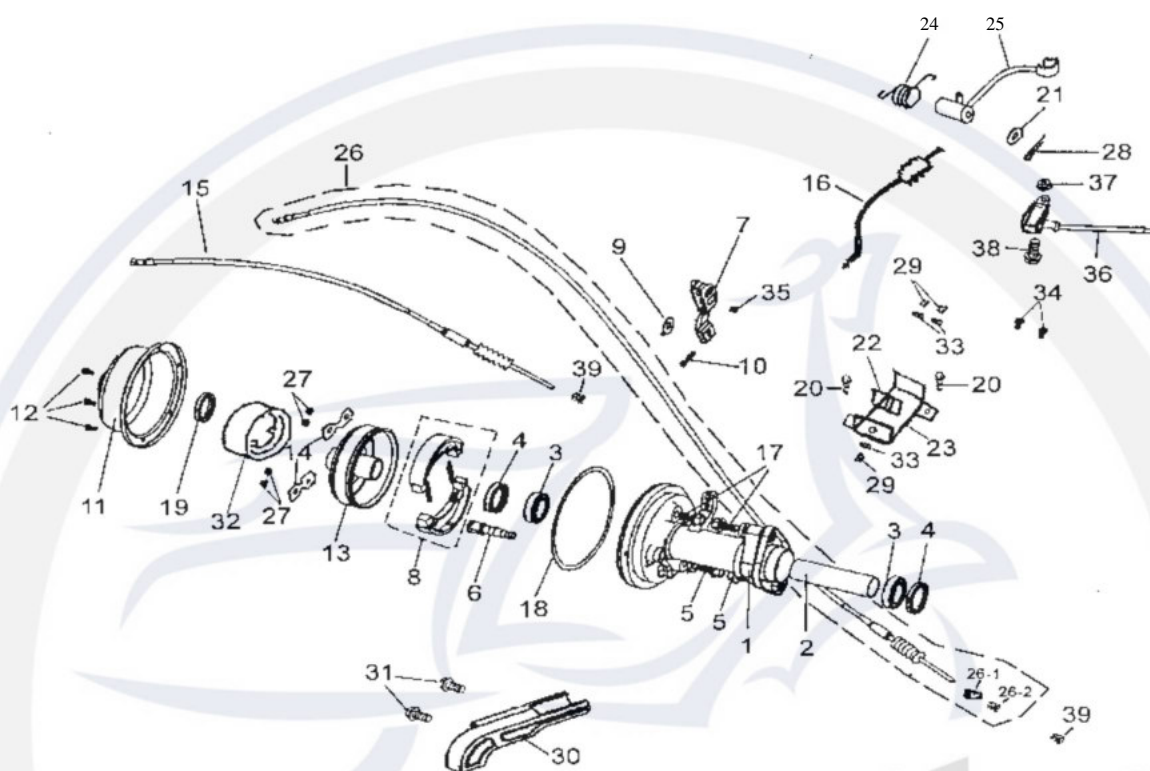

P/N	DESCRIPTION	PART.NO.	Q'TY	REMARK
26-1	REAR WHEEL AXLE FIX SEAT	42805-159-000	1
26-2	SPACER COLLAR	42810-156-000	1	42*35.5*143.2
26-3	BEARING	96100-6007ZZ	2	6007ZZ NTN
26-4	OIL SEAL	96500-426208	2	42*62-8
26-5	HEX FLANGE BOLT	96000-12038-C	2	M 12*125*38
26-6	REAR BRAKE CAM SHAFT	43141-156-000	1	
26-7	REAR BRAKE ARM	43410-159-001	1
26-8	REAR BRAKE SHOE COMP	43120-156-001	1	
26-9	BRAKE GUIDE	45144-156-000	1	
26-10	HEX FLANGE BOLT	96000-06032-10C	1	M6x32
26-11	REAR BRAKE DRUM COVER	43519-156-000	1	
26-12	PAN PHILLIPS BOLT	93501-06010-K	3	M6X10
26-13	REAR BRAKE DRUM	43520-156-000	1	
26-14	BRAKE DRUM FIX WASHER	43522-156-000	2	«
26-15	REAR BRAKE CABLE-HAND	43449-159-000	1	
26-16	REAR BRAKE CABLE-FOOT	43451-159-000	1	
26-17	HEX FLANGE BOLT	96000-12032-C	2	M12*32
26-18	O-RING	91321-156-000	1	
26-19	OIL SEAL	96500-355007	^1	
26-20	FLAT HEAD PHILLIPS BOLT	93902-06008-B	2	M6*8
26-21	PLAIN WASHER	94101-1225020-C	1	12.5*25*2
26-22	CONNECTER WIRE LEVELR	45452-133-000	1	
26-23	CONNECTER WIRE SEAT	45453-133-000	1	
26-24	SPRING	43421-156-000	1	
26-25	PENDAL BRAKE LEVER	43454-133-000	1	
26-26	REAR BRAKE CABLE	43450-159-000	1

26-26-1	REAR BRAKE FIXTUBE	95015-31001	2	
26-26-2	BRAKE ADJUST NUT	95015-41000	2	
26-27	HEX NUT	94001-08000-K	4	M8*1.25
26-28	COTTER PIN	94201-24190	1	
26-29	INSERT BOLT	45421-133-000	3	
26-30	REAR COVER	40550-156-000	1	
26-31	HEX FLANGE BOLT	96000-08012-K	2	M8X12
26-32	NOISE ELIMINATION RING	43524-156-000	1	
26-33	INSERT NUT	45422-133-000	3	
26-34	HEX BOLT WITH FIX WASHER	92000-06016-K	2	M6X12
26-35	HEX NUT	94001-06000-C	1	M6
26-36	TOUCH SWITCH	34912-156-001	1	
26-37	HEX NUT	94001-03000-K	1	M3
26-38	PAN PHILLIPS BOLT WITH WASHER	93501-03010-K	1	M3*10
26-39	HEX NUT	94001-06000-C	2	

Motorroller.de
- seit 1993 -

Aktuelle Preise erfahren sie auf www.motorroller.de

D-27 HANDLE STEERING COMP ODGD

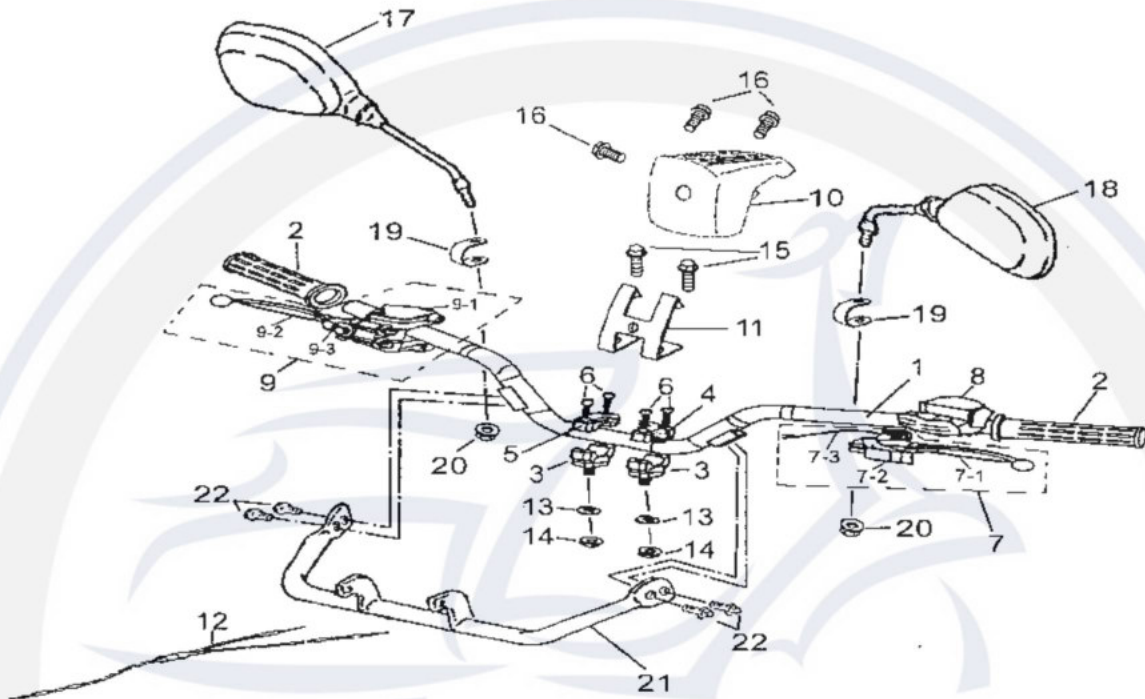

P/N	DESCRIPTION	PART NO.	Q'TY	REMARK
27-1	HANDLE BAR COMP	53100-159-000	1	
27-2	HANDLE GRIP	53165-131-000	2	
27-3	HANDLE BAR CLAMP SADDLE	53200-131-000	2	
27-4	HANDLE BAR CLAMP COVER (L)	53210-131-000	1	
27-5	HANDLE BAR CLAMP COVER (R)	53220-131-000	1	
27-6	HEX SOCKET BOLT	91000-06025-K	4	M6x25
27-7	LEFT LEVER ASS'Y	53171-156-000	1	
27-7-1	L. SIDE LEVER	53178-131-000	1	
27-7-2	HAND BRAKE PIECE	53179-131-000	1	
27-7-3	BRAKE SENSOR SWITCH CABLE	53173-131-000	1	
27-8	L. SWITCH ASS'Y	35151-133-000	1	
27-9	RIGHT LEVER ASS'Y	53172-131-00A	1	
27-9-1	R. SIDE LEVER SEAT	53176-131-000	1	
27-9-2	R. SIDE LEVELR	53175-131-000	1	
27-9-3	CABLE STABILIZER	53177-131-000	1	
27-10	HANDLE BAR UPPER POD	64213-159-000	1	
27-11	PROTECT COVER FIX PLATE	53310-157-000	1	
27-12	THROTTLE CABLE	17910-156-000	1	
27-13	PLAIN WASHER	94101-1022020-C	2	10x22x2
27-14	NYLON INSERT LOCK NUT	90350-10000-C	2	M10
27-15	HEX FLANGE BOLT	96000-06012-K	2	M6x12
27-16	PAN PHILLIPS BOLT	93100-05012-K	3	M5x12
27-17	R.BACK VIEW MIRROR	88110-131-000	1	
27-18	L.BACK VIEW MIRROR	88120-131-000	1	
27-19	REARVIEW FIXED PIECE	88130-131-000	2	
27-20	NYLON INSERT LOCK NUT	90350-08000-C	2	
27-21	HEAD- LIGHT SUPPORT ROD	53112-159-000	1	
27-22	HEX FLANGE BOLT	96000-06012-K	4	
27-23	STRAP	90768-151-000	2	

D-28 REAR WHEEL A XU

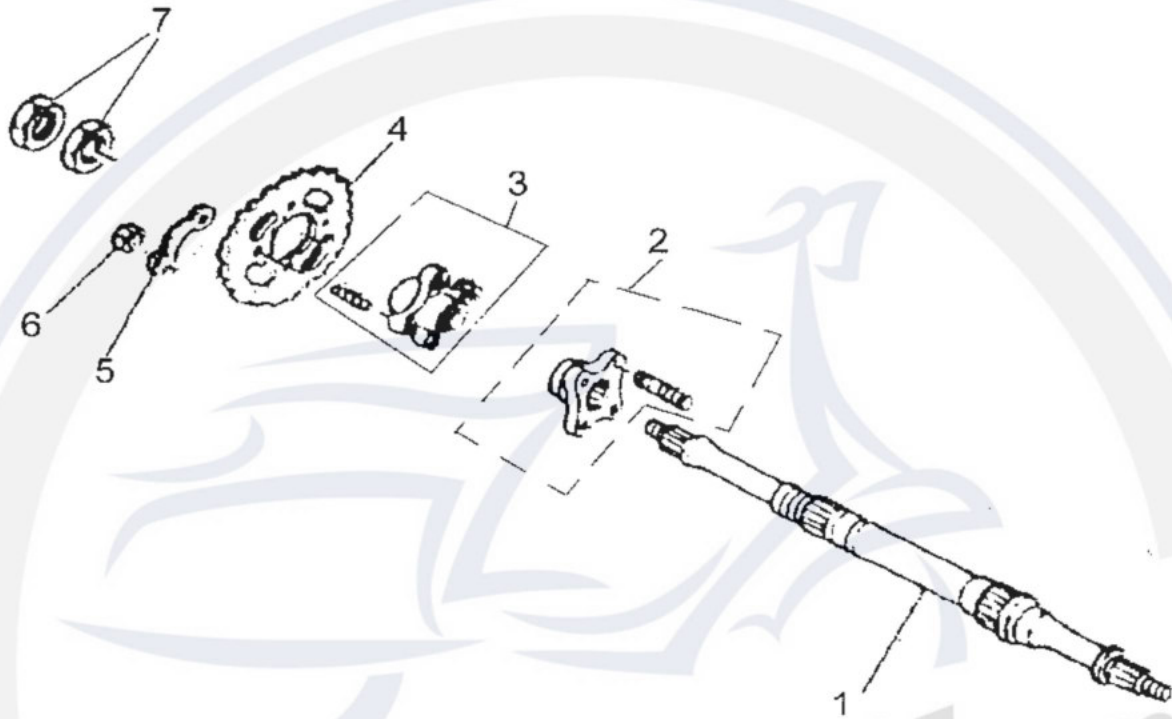

P/N	DESCRIPTION	PART.NO.	Q'TY	REMARK
28-1	REAR AXLE	97000-156-001	1	
28-2	CONNECTING BRAKE DRUM SEAT	97050-156-000	1	
28-3	FINAL DRIVE SPROCKET HOLDER SET	41210-156-000	1	
28*4	FINAL DRIVE SPROCKET	41201-156-000	1	32T 520
28-5	FINAL DRIVE SPROCKET WASHER	41202-156-000	2	
28-6	HEX NUT	94002-10000-C	4	M10X1.25-17
28-7	HEX NUT	94001-33000-K	2	M33X1.5

"L-IN UW»*-

Telesuch Quad 1000

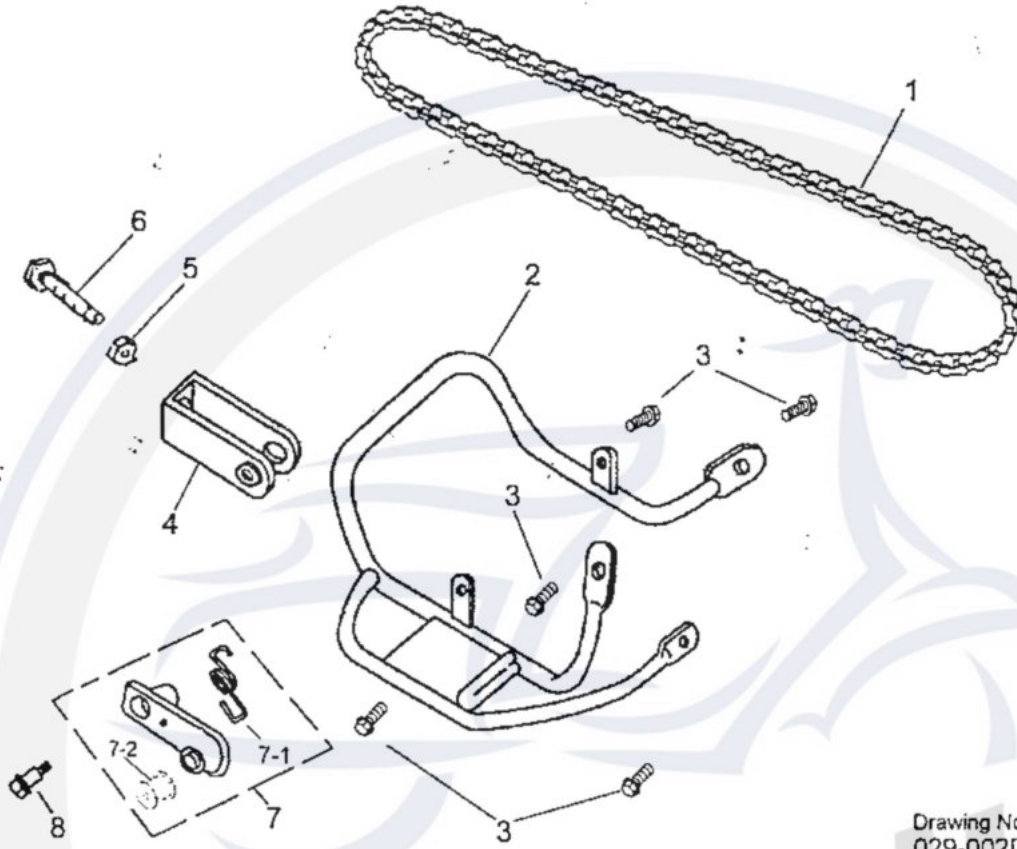

Drawing No:
029-002D

SALES MARK	P/N	UtBLKiPnO N	PART NO.	POLARIS NO.	CHINESE	Q"TY	"KEMAK" K
販賣記號	ft=«	3?3££ifg	3*P JUg plj dpw S/i	客戶番號	中文名稱	ffli	真注
	29-1	PRIVE CHAIN ASST	40530-159-001		mmms.	i	520;72
	29-2	PROTECT COVER	40520-156-000		後鏈輪保護蓋	1	
	29-3	HEX FLANGE BOLT	96000-08016-K		六角緣面螺栓	5	M8X16
	29-4	ADJUSTER , CHAIN	40543-156-000		ÜllMfJtff	1	
	29-5	HEX FLANGE NUT	94050-08000- C		六角緣面螺帽	1	M8XI.25
	29-6	HEX BOLT	B		六角螺栓 (全牙)	1	M8x60
	29-7	CHAIN SUPPORTER	40540-156-002		a&s&ss	1	10T
	29-7-1	RETURN SPRING	40541-156-000		mm	1	
	29-7-2	PLASTIC ROLLER	40545-156-000		gf&s&ä	1	
	29-3	HEX FLANGE BOLT	90108-153-000		-/smmmfe	1	

Aktuelle Preise erfahren sie auf www.motorroller.de

S,t%. 31 - N4

D-29 CHAIN

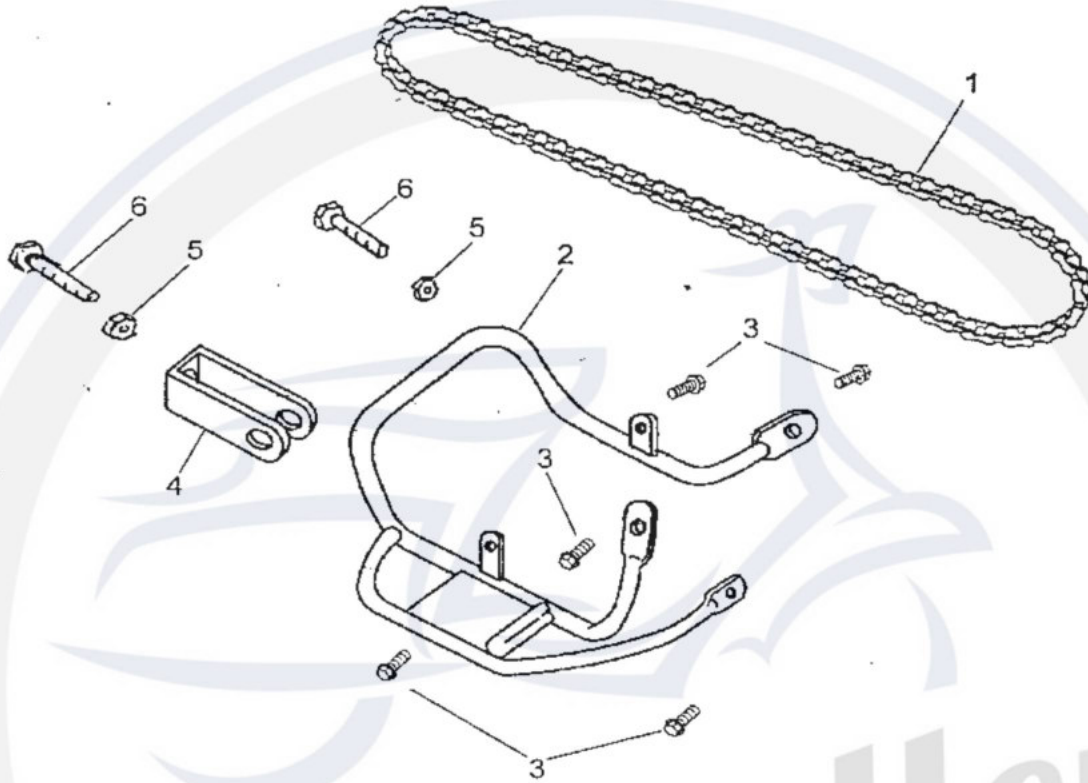

P/N	DESCRIPTION	PART.NO,	Q'TY	REMARK
29-1	PRIVE CHAIN ASSY	40530-159-000	1	520;70
29-2	Protect cover	40520-156-000	1	
29-3	HEX FLANGE BOLT	96000-08016-K	5	M8X16
29-4	ADJUSTER , CHAIN	40543-156-000	1	
29-5	HEX FLANGE NUT	94050-08000-C	2	M8x1.25
29-6	HEX BOLT	92000-08060-B	2	M8x60

30-12	NUCKLE SET (L)	51325-156-001	1	
30-12-1	NUCKLE HOLD	51315-156-000	4	
30-12-2	SPACER RING	51316-156-000	2	10.5*17*73.5
30-12-3	NUCKLE (L)	51310-156-001	1	
30-12-4	GREASE VALVE	51300-131-000	2	
30-12-5	GREASE VALVE RUBBER CAP	51301-131-000	2	
30-13	NUCKLE SET (R)	51330-156-001	1	
30-13-1	NUCKLE (R)	51320-156-001	1	
30-14	HEX FLANGE BOLT WITH HOLD	96200-10105-K	2	10*105
30-15	SPRING WASHER	51319-156-000	1	
30-16	SPACE RING	51317-156-000	2	9x14x42
30-17	PLAIN WASHER	94101-1022020-C	1	10*22*2

Motorroller.de
- seit 1993 -

D-31 HEAD LIGHT , TAIL LIGHT (LID LI

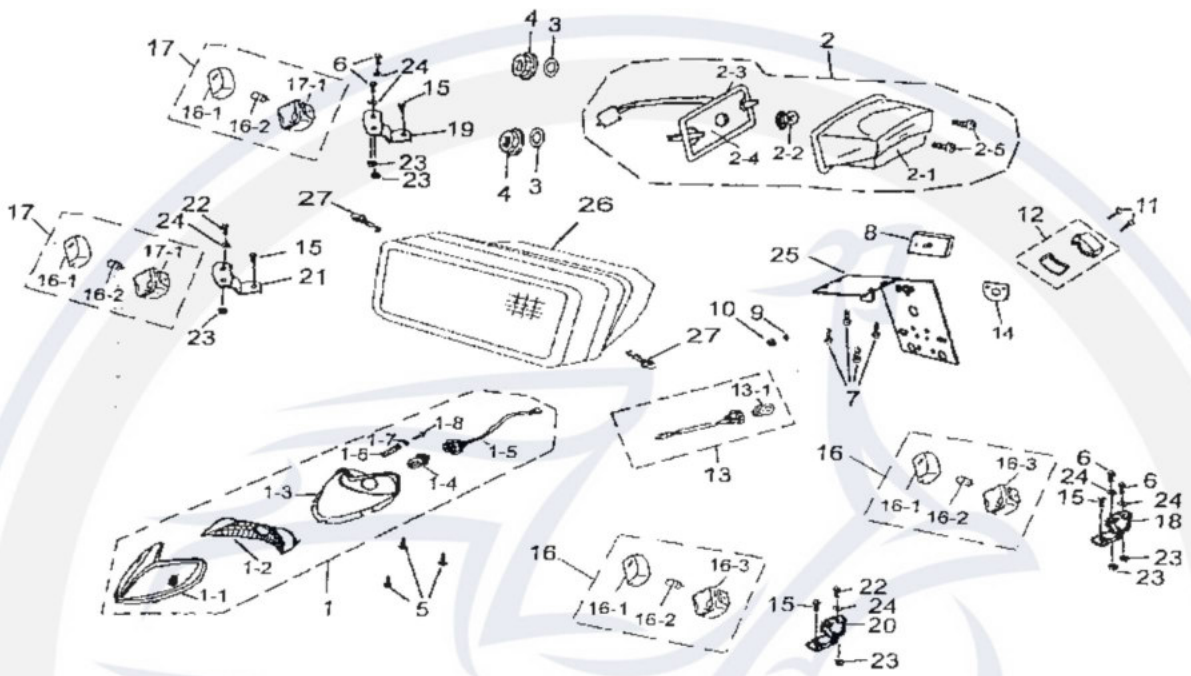

P/N	DESCRIPTION	PART.NO.	Q'TY	REMARK
31-1	HEAD LIGHT ASS'Y	33100-157-000	1	
31-1-1	HEAD LIGHT LENS	33110-157-000	1	
31-1-2	HEAD LIGHT REFLECTOR	33104-157-000	1	
31-1-3	HEAD LIGHT SEAT	33111-157-000	2	
31-1-4	BULB	34907-157-000	1	12V-35W 135W
31-1-5	HEAD LIGHT CABLE	33715-157-000	1	
31-1-6	HEAD LIGHT ADJUSTABLE SPRING	33101-131-000	1	
31-1-7	PLAIN WASHER	94101-0613010-C	1	6*13*1
31-1-8	TAPPING SCREW	93903-05044-C	1	M5*44
31-2	TAIL LIGHT ASS'Y	33700-131-00A	1	E mark
31-2-1	TAIL LIGHT LENS	33702-131-00A	1	E mark
31-2-2	HEAD LIGHT BULB	33906-116-00A	1	E mark 21/5 W
31-2-3	WATERPROOF GASKET	33716-131-000	1	
31-2-4	REAR LIGHT SOCKET	33711-131-00A	1	E-MARK
31-2-5	PAN PHILLIPS BOLT	93500-04035-SUS	2	M4*35
31-3	PLAIN WASHER	94101-0619010-C	2	6*19*1
31-4	HEX FLANGE NUT	94050-06000-C	2	M6
31-5	TAPPING SCREW	93903-05016-K	3	M5x16
31-6	PAN PHILLIPS BOLT	93100-05016-K	4	
31-7	HEX FLANGE BOLT	96000-06012-K	4	M6X12
31-8	REFLECCTOR	33741-131-000	1	
31-9	PLAIN WASHER	94101-0519010-C	1	
31-10	HEX FLANGE NUT	94050-05000-C	1	
31-11	PAN PHILLIPS BOLT	93500-04040-K	2	
31-12	LICENSE LIGHT COVER	33710-131-000	-1	
31-13	LICENSE LIGHT SEAT	33713-131-000	1	
31-13-1	LICENSE BULB	33709-131-000	1	
31-14	ANTI-WATER RUBBER	33707-131-000	1	
31-15	HEX FLANGE BOLT	96000-05016-K	4	M5X16
31-16	L. FRONT SIGNAT ASS'Y	33450-116-00A	2	
31-16-1	FRONT SIGNAL COVER	33402-116-000	4	
31-16-2	BULB	33905-116-000	4	12V/10W

Aktuelle Preise erfahren sie auf www.motorroller.de

31-16-3	LEFT FRONT SINGAL SEAT	33451-116-000	2	
31-17	RIGHT FRONT SINGAL ASS'Y	33400-116-00A	2	E mark
31-17-1	RIGHT FRONT SINGAL ASS'Y	33401-116-000	2	
31-18	L SIGNAL FIXED PLATE	33405-119-000	1	
31-19	R. SIGNAL FIXED PLATE	33404-119-000	1	
31-20	L. FRONT SIGNAL FIXED PLATE	33410-162-000	1	
31-21	R. FRONT SIGNAL FIXED PLATE	33409-162-000	1	
31-22	PAN PHILLIPS BOLT	93100-05D12-K	2	
31-23	NYLON INSERT LOCK NUT	90350-05000-K	6	M 5
31-24	PLAIN WASHER	94101-0514010-K	6	05x014x1.
31-25	LICENSE BRACKET	80116-131-000	1	
31-26	HEADLIGHT	33114-159-000	1	
31-27	HEX FLANGE BOLT	96000-08025-K	2	M 8*25

Motorroller.de
- seit 1993 -

D-32 GENERATOR, START MOTOR

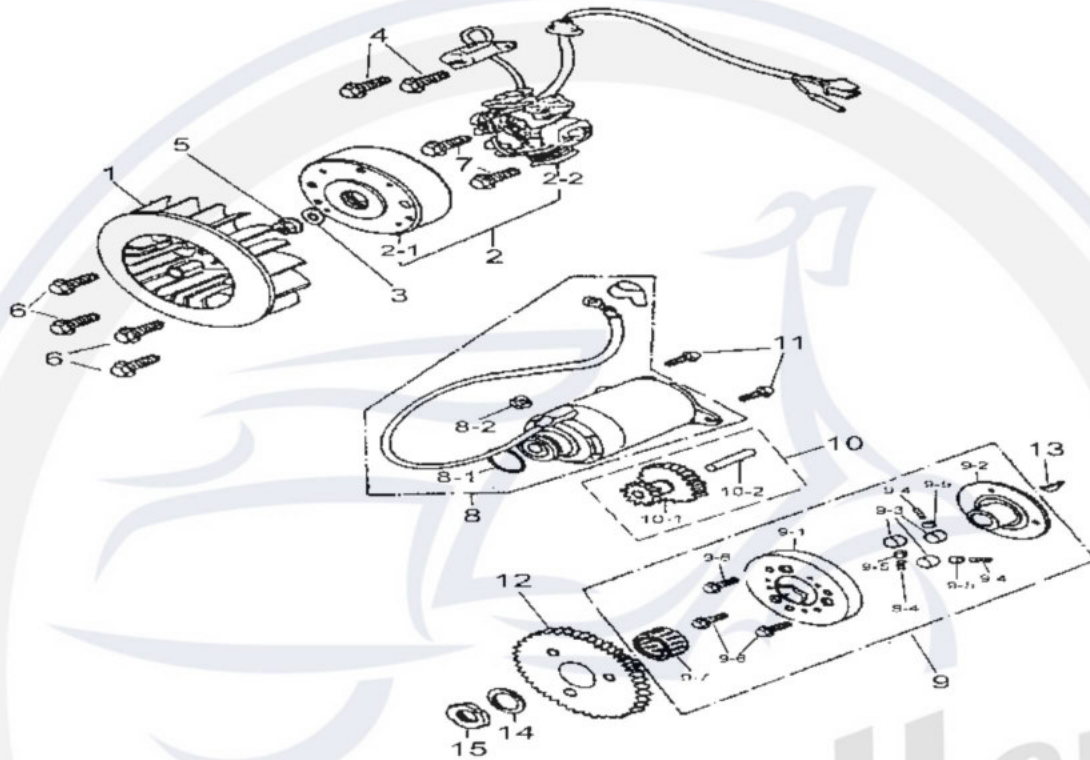

P/N	DESCRIPTION	PART. NO.	CfTY	REMARK
32-1	FAN	19510-119-000	1	
32-2	GENERATOR ASS'Y	31100-119-000	1	
32-2-1	GENERATOR FACE FLY WHEEL	31110-119-000	1	
32-2-2	STATOR COMP	31120-119-000	1	
32-3	PLAIN WASHER	94101-1225023-C	1	12X25X2.3
32-4	HEX BOLT	92000-05012-C	2	M 5X12
32-5	HEX FLANGE NUT	94050-12000-C	1	M 12
32-6	HEX FLANGE BOLT	96000-06018-8C	4	M 6X18
32-7	HEX FLANGE BOLT	96000-06020-8C	2	M 6X20
32-8	STARTING MOTOR ASS'Y	31200-119-000	1	
32-8-1	OIL RING	31200-119-001	1	
32-8-2	HEX FLANGE NUT	31200-119-002	1	
32-9	STARTING CLUTCH ASS'Y	28410-119-000	1	
32-9-1	CLUTCH COVER COMP	28120-119-000	1	
32-9-2	FLANGE STARTING CLUTCH	28125-119-000	1	
32-9-3	CLUTCH ROLLER	28411-119-000	3	
32-9-4	CLUTCH SPRING	28413-119-000	3	
32-9-5	CLUTCH GUIDER	28412-119-000	3	
32-9-6	HEX SOCKET BOLT	91000-06012-C	3	M 6X12
32-9-7	NEEDLE BEARING	96200-283217	1	
32-10	GEAR STARTER REDUCTION ASS'Y	28422-119-000	1	
32-10-1	GEAR STARTER REDUCTION	28423-119-000	1	
32-10-2	SHAFT STARTER REDUCTION GEAR	96300-119-000	1	
32-11	HEXFLAINGE BOLT	96000-06018-8C	2	
32-12	GEAR COMP STARTING CLUTCH	28220-119-000	1	
32-13	SEMICYCLE KEY	90471-119-000	1	
32-14	PLAIN WASHER	94101-2231025-C	1	22X31X2.5
32-15	NUT	94071-22000-C	1	M 22

Aktuelle Preise erfahren sie auf www.motorroller.de

D-33 ELECTRICAL PARTS

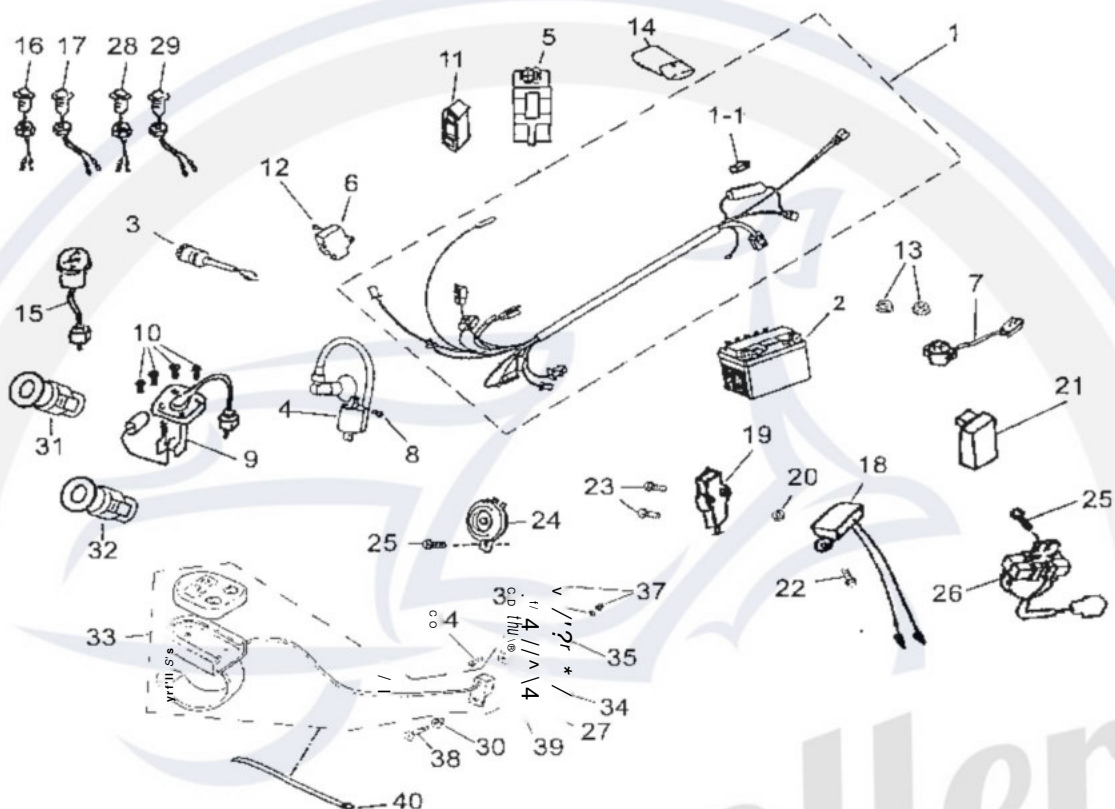

P/N	DESCRIPTION	PART.NO.	Q'TY	REMARK
33-1	MAIN WIRE ASS'Y	32100-159-001	1	
33-1-1	FUSE	98200-156-000	1	15A
33-2	BATTERY	31500-156-000	1	9A
33-3	MAIN SWITCH ASS'Y	35100-131-00F	1	
33-4	IGNITION COIL ASS'Y	30510-119-000	1	
33-5	C.D.I. UNIT ASS'Y	30410-159-000	1	
33-6	RECTIFIER®ULATOR	31600-119-000	1	
33-7	STARTER RELAY ASS'Y.	38501-119-000	1	
33-8	HEX FLANGE BOLT	96000-05020-C	1	M 5x20
33-9	PETROL GAUGE ASS'Y	37800-156-000	1	
33-10	HEX FLANGE BOLT	96000-05016-K	4	M 5x16
33-11	FIX RUBBER	30411-156-000	1	
33-12	HEX FLANGE BOLT	96000-06012-K	1	M 6'12
33-13	HEX FLANGE NUT	9405 0-06000-K	2	M 6
33-14	TOOL BAG	50120-119-000	1	
33-15	PETROL GUIDE ASS'Y	37802-156-000	1	
33-16	NEUTRAL INDICATOR	34910-158-000	1	Green
33-17	TROUBLE INDICATOR	34915-159-000	1	
33-18	NEUTRAL INDICATOR SWITCH	34912-156-001	1	
33-19	REVERSE INDICATOR SWITCH	34913-156-000	1	
33-20	HEX NUT	94001-03000-K	1	M 3
33-21	INDICATOR CONTROL	34914-156-000	1	
33-22	PAN PHILLIPS BOLT WITH WASHER	93501-03010-K	1	M 3x10
33-23	HEX SOCKET BOLT	91000-05016-K	2	M 5x16
33-24	HORN (E-MARK)	38110-119-000	1	

Aktuelle Preise erfahren sie auf www.motorroller.de

33-25	HEX WASHER FACE BOLT	96000-Ü6012-K	2	M 6x12
33-26	RESISTOR	38601-111-000	1	
33-27	NYLON INSERT LOCK NUT	90350-05000-K	1	M 5
33-28	LOW BEAM INDICATOR	34907-159-000	1	
33-29	HIGH BEAM INDICATOR	34910-159-000	1	
33-30	NYLON INSERT LOCK NUT	90350-08000-K	1	M 8
33-31	SIGNAL BUZZER	38301-111-000	1	
33-32	SIGNAL WARNER	38302-133-000	1	
33-33	SPEEDOMETER ASS'Y	37200-159-000	1	
33-34	PAN PHILLIPS BOLT	93500-04016-K	2	M 4'16
33-35	SPEEDOMETER FIXED PLATE	37201-159-000	1	
33-36	PLAIN WASHER	94101-0412010-K	2	4'12'1
33-37	NYLON INSERT LOCK NUT	90350-04000-K	2	M 4
33-38	PAN PHILLIPS BOLT	93500-05016-K	1	M 5'16
33-39	PLAIN WASHER	94101-0514010-K	1	5'14'1
33-40	STRAP	90768-151-000	1	

Motorroller.de
- seit 1993 -

Aktuelle Preise erfahren sie auf www.motorroller.de

D-34 DECALS

P/N	DESCRIPTION	PART.NO.	Q'TY	REMARK
34-1	DECAL-FRONT FENDER (R)	87722-163-00A	1	Cobra
34-2	DECAL-FRONT FENDER (L)	87723-163-00A	1	Cobra
34-3	DECAL-FUEL TANK (R)	87720-157-00A	1	Cobra
34-4	DECAL-FUEL TANK(L)	87721-157-00A	1	Cobra
34-5	DECAL-REAR FENDER (R)	87730-163-00A	1	Cobra
34-6	DECAL-REAR FENDER (L)	87731-163-00A	1	Cobra
34-7	DECAL- RIGHT REAR FENDER	87747-163-00A	1	Cobra
34-8	DECAL- LEFT REAR FENDER	87748-163-00A	1	Cobra
34-9	DECAL-WARING (Y-16)	87751-159-000	1	
34-10	DECAL-WARING	87752-159-000	1	
34-11	DECAL-REVERSE WARING	87754-156-000	1	
34-12	DECAL-WARING CHAIN	87758-156-000	1	
34-13	DECAL-VIN CODE	87771-074029	1	

Motorroller.de
- seit 1993 -

D-35 STANDARD ACCESSORY

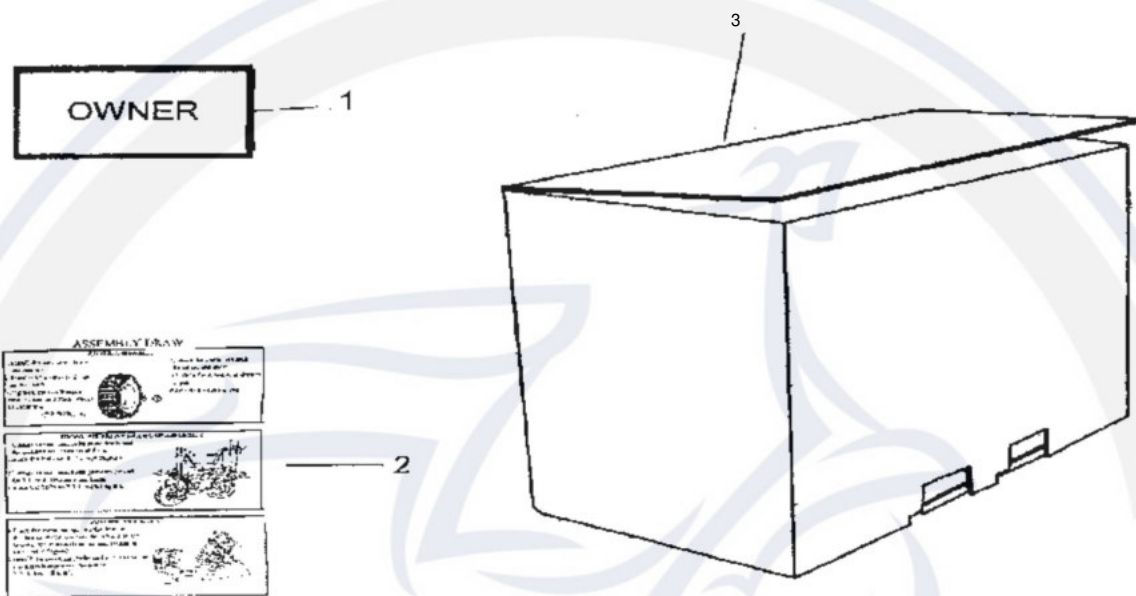

P/N	DESCRIPTION	PART. NO.	TTY	REMARK
35-1	OWNERS MANUAL	OWNER-159	1	
35-2	ASSEMBLY DRAW	ASS-162A	1	
35-3	LOCK	35120-159-000	1	010.
35-4	PACKING	89005-157-000	1	